

Axial piston variable motor

A6VM series 71

Americas

RE-A 91610

Edition: 12.2015

Replaces: 04.2013

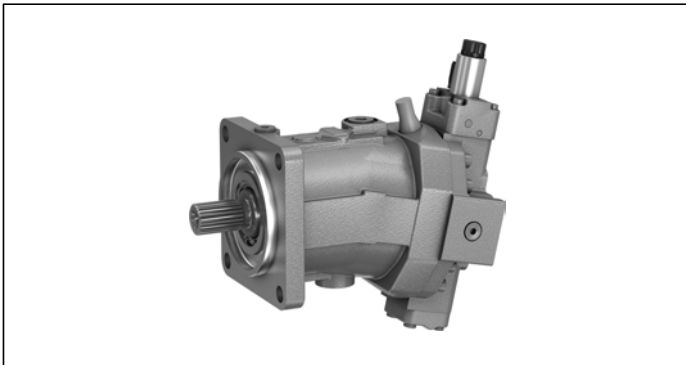

- ▶ Sizes 60 to 215
- ▶ Nominal pressure 6500 psi (450 bar)
- ▶ Maximum pressure 7250 psi (500 bar)
- ▶ Open and closed circuits

Features

- ▶ Variable motor with axial tapered piston rotary group of bent-axis design, for hydrostatic drives in open and closed circuit
- ▶ For use in mobile and stationary applications
- ▶ The wide control range enables the variable motor to satisfy the requirement for high speed and high torque.
- ▶ The displacement can be infinitely varied from $V_{g \max}$ to $V_{g \min} = 0$.
- ▶ The output speed is dependent on the flow of the pump and the displacement of the motor.
- ▶ The output torque increases with the pressure differential between the high and low-pressure side and with increasing displacement.
- ▶ Wide control range with hydrostatic transmissions
- ▶ Wide selection of control devices
- ▶ Cost savings through elimination of gear shifts and possibility of using smaller pumps
- ▶ Compact, robust motor with long service life
- ▶ High power density
- ▶ Good starting efficiency
- ▶ Version with 9-piston rotary group
- ▶ Good low speed characteristics
- ▶ High uniformity

Contents

Type code	2
Hydraulic fluids	5
Flow direction	6
Shaft seal	6
Operating pressure range	7
Technical data	8
HP – Proportional hydraulic control	10
EP – Proportional electric control	13
HZ – Two-point hydraulic control	15
EZ – Two-point electric control	16
HA – Automatic high-pressure related control	17
DA – Automatic speed-related control	22
Electric travel direction valve (for DA, HA.R)	24
Dimensions size 60	25
Dimensions size 85	31
Dimensions size 85	32
Dimensions size 115	38
Dimensions size 150	44
Dimensions size 170	50
Dimensions size 215	56
Connector for solenoids	62
Flushing and boost pressure valve	63
Counterbalance valve BVD and BVE	65
Speed sensor	69
Setting range for displacement	70
Installation instructions	72
Project planning notes	74
Safety instructions	75

Type code

01	02	03	04	05	06	07	08	09	10	11	12	13	14	15	16	17	18	19	20	21	
A6V	M					0	0			/	71	A	W	V	0					-	

Axial piston unit

01	Bent-axis design, variable, nominal pressure 6500 psi (450 bar), maximum pressure 7250 psi (500 bar)	A6V
----	--	------------

Operating mode

02	Motor	M
----	-------	----------

Size (NG)

03	Geometric displacement, see technical data on page 8	in cm ³ /rev	060	085	115	150	170	215
		in in ³ /rev	3.66	5.19	7.02	9.15	10.37	13.12

Control device

				060	085	115	150	170	215		
04	Proportional control hydraulic	positive control	$\Delta p_{St} = 145 \text{ psi (10 bar)}$	•	•	•	•	•	•	HP1	
			$\Delta p_{St} = 365 \text{ psi (25 bar)}$	•	•	•	•	•	•	HP2	
		negative control	$\Delta p_{St} = 145 \text{ psi (10 bar)}$	•	•	•	•	•	•	•	HP5
			$\Delta p_{St} = 365 \text{ psi (25 bar)}$	•	•	•	•	•	•	•	HP6
	Proportional control electrical	positive control	$U = 12 \text{ V DC}$	•	•	•	•	•	•	•	EP1
			$U = 24 \text{ V DC}$	•	•	•	•	•	•	•	EP2
		negative control	$U = 12 \text{ V DC}$	•	•	•	•	•	•	•	EP5
			$U = 24 \text{ V DC}$	•	•	•	•	•	•	•	EP6
	Two-point control hydraulic	negative control		-	-	-	•	•	•	•	HZ5
				•	•	•	-	-	-	-	HZ7
	Two-point control electrical	negative control	$U = 12 \text{ V DC}$	-	-	-	•	•	•	•	EZ5
			$U = 24 \text{ V DC}$	-	-	-	•	•	•	•	EZ6
$U = 12 \text{ V DC}$			•	•	•	-	-	-	-	EZ7	
$U = 24 \text{ V DC}$			•	•	•	-	-	-	-	EZ8	
Automatic control high-pressure related, Positive control	with minimum pressure increase	$\Delta p \leq \text{approx. } 145 \text{ psi (10 bar)}$	•	•	•	•	•	•	•	HA1	
	with pressure increase	$\Delta p = 1450 \text{ psi (100 bar)}$	•	•	•	•	•	•	•	HA2	
Automatic control speed related, negative control $p_{St} / p_{HD} = 5/100$	hydr. travel direction valve		•	•	•	•	•	•	•	DA0	
	electric travel direction valve + electric $V_{g \max}$ circuit	$U = 12 \text{ V DC}$	•	•	•	•	•	•	•	DA1	
		$U = 24 \text{ V DC}$	•	•	•	•	•	•	•	DA2	

Pressure control/override

				060	085	115	150	170	215		
05	Without pressure control/override			•	•	•	•	•	•	00	
	Pressure control fixed setting, only for HP5, HP6, EP5 and EP6			•	•	•	•	•	•	D1	
	Override of controls HA1 and HA2	hydraulic remote control, proportional			•	•	•	•	•	•	T3
		electric, two-point	$U = 12 \text{ V DC}$	•	•	•	•	•	•	•	U1
			$U = 24 \text{ V DC}$	•	•	•	•	•	•	•	U2
		electric and travel direction valve, electric	$U = 12 \text{ V DC}$	•	•	•	•	•	•	•	R1
			$U = 24 \text{ V DC}$	•	•	•	•	•	•	•	R2

Connector for solenoids¹⁾ (see page 62)

06	Without connector (without solenoid, only for hydraulic control)	0
	DEUTSCH - molded connector, 2-pin, without suppressor diode	P

• = Available ◦ = On request - = Not available

1) Connectors for other electric components can deviate.

01	02	03	04	05	06	07	08	09	10	11	12	13	14	15	16	17	18	19	20	21	
A6V	M					0	0			/	71	A	W	V	0					-	

Additional function 1

07	Without additional function	0
----	-----------------------------	----------

Additional function 2

08	Without additional function	0
----	-----------------------------	----------

Response time damping (for selection, see control)

09	Without damping (standard with HP and EP)	0	
	Damping	HP, EP, HP5,6D. and EP5,6D., HZ, EZ, HA with counterbalance valve BVD/BVE	1
		One-sided in inlet to large stroking chamber (HA)	4
		One-sided in outlet from large stroking chamber (DA)	7

Setting range for displacement²⁾

10	V _{g max} -setting screw	V _{g min} -setting screw	060	085	115	150	170	215		
	Without setting screw	short (0-adjustable)	●	●	●	●	●	●	A	
		medium	●	●	●	●	●	●	B	
		long	●	●	●	●	●	●	C	
		extra long	-	●	●	●	●	●	D	
	Short	short (0-adjustable)	●	●	●	●	●	●	●	E
		medium	●	●	●	●	●	●	●	F
		long	●	●	●	●	●	●	●	G
		extra long	-	●	●	●	●	●	●	H
	Medium	short (0-adjustable)	●	●	●	●	●	●	●	J
		medium	●	●	●	●	●	●	●	K
		long	●	●	●	●	●	●	●	L
		extra long	-	●	●	●	●	●	●	M

Series

11	Series 7, index 1	71
----	-------------------	-----------

Configuration of ports and fastening threads

12	ANSI, port threads with O-ring sealing according to ISO 11926	A
----	---	----------

Direction of rotation

13	Viewed on drive shaft, bidirectional	W
----	--------------------------------------	----------

Sealing material

14	FKM (fluoroelastomer)	V
----	-----------------------	----------

Drive shaft bearing

15	Standard bearing	0
----	------------------	----------

Mounting flange

16	SAE J744		060	085	115	150	170	215	
		127-4	●	●	-	-	-	-	C4
		127-2	-	●	-	-	-	-	C2
		152-4	-	-	●	●	●	-	D4
		165-4	-	-	-	-	-	●	E4

● = Available ○ = On request - = Not available

²⁾ The settings for the setting screws can be found in the table (see pages 70 and 71).

4 **A6VM series 71** | Axial piston variable motor
Type code

01	02	03	04	05	06	07	08	09	10	11	12	13	14	15	16	17	18	19	20	21	
A6V	M					0	0		/	71	A	W	V	0						-	

Drive shaft		060	085	115	150	170	215		
17	Splined shaft ANSI B92.1a	1 1/4 in 14T 12/24 DP	●	-	-	-	-	S7	
		1 1/2 in 17T 12/24 DP	-	●	-	-	-	S9	
		1 3/4 in 13T 8/16 DP	-	-	●	●	-	-	T1
		2 in 15T 8/16 DP	-	-	-	○	●	●	T2

Port plate for working ports		060	085	115	150	170	215		
18	SAE working ports A and B at rear	●	●	●	●	●	●	1	
	SAE working ports A and B at side, opposite	●	●	●	●	●	●	2	
	Port plate with 1-stage pressure limitation valves for mounting a counterbalance valve ³⁾	BVD20	●	●	●	-	-	-	7
		BVD25, BVE25	-	-	●	●	●	●	8

Valve (see pages 63 to 68)		060	085	115	150	170	215		
19	Without valve	●	●	●	●	●	●	0	
	With counterbalance valve BVD/BVE mounted ⁴⁾	●	●	●	●	●	●	W	
	With flushing and boost pressure valve, mounted	Flushing flow q_v [gpm (l/min)]							
	Flushing on both sides	0.9 (3.5)	●	●	●	-	-	-	A
	Flushing flow at: $\Delta p = p_{ND} - p_G = 365 \text{ psi (25 bar)}$ and $v = 60 \text{ SUS (10 mm}^2/\text{s)}$	1.3 (5)	●	●	●	-	-	-	B
		2.1 (8)	●	●	●	●	●	●	C
	$(p_{ND} = \text{low pressure, } p_G = \text{case pressure})$	2.6 (10)	●	●	●	●	●	●	D
	Only possible with port plates 1 and 2	3.7 (14)	●	●	●	-	-	-	F
		4.0 (15)	-	-	● ⁵⁾	●	●	●	G
		4.8 (18)	-	-	● ⁵⁾	●	●	●	I
		5.5 (21)	-	-	● ⁵⁾	●	●	●	J
		7.1 (27)	-	-	● ⁵⁾	●	●	●	K
		8.2 (31)	-	-	● ⁵⁾	●	●	●	L
	9.7 (37)	-	-	-	●	●	●	M	

Speed sensor (see page 69)		060	085	115	150	170	215	
20	Without speed sensor	●	●	●	●	●	●	0
	Prepared for speed sensor DSM/DSA	●	●	●	●	●	●	U
	With speed sensor DSM/DSA mounted ⁶⁾	●	●	●	●	●	●	V

Standard / special version			
21	Standard version		0
	Standard version with installation variants, e. g. T ports against standard open and closed		Y
	Special version		S

● = Available ○ = On request - = Not available

Notes

- ▶ Note the project planning notes on page 74.
- ▶ When ordering, please provide the relevant technical data additionally to the type code

3) Only possible in conjunction with HP, EP and HA control. Note the restrictions described on page 65.

4) State ordering code for counterbalance valve separately in accordance with data sheet 95522 for BVD or 95525 for BVE. Note the restrictions described on page 65.

5) Not for EZ7, EZ8 and HZ7.

6) State ordering code for sensor separately in accordance with data sheet 95132 for DSM or 95133 for DSA and note the requirements relating to the electronics.

Hydraulic fluids

The variable motor A6VM is designed for operation with mineral oil HLP according to DIN 51524.

Application instructions and requirements for hydraulic fluids should be taken from the following data sheets before the start of project planning:

- ▶ 90220: Hydraulic fluids based on mineral oils and related hydrocarbons
- ▶ 90221: Environmentally acceptable hydraulic fluids
- ▶ 90222: Fire-resistant, water-free hydraulic fluids (HFDR/HFDU)
- ▶ 90223: Fire-resistan, water-containing hydraulic fluids (HFAE, HFAS, HFB, HFC)

Details regarding the selection of hydraulic fluid

The hydraulic fluid should be selected such that the operating viscosity in the operating temperature range is within the optimum range (ν_{opt} see selection diagram).

Note

At no point of the component may the temperature be higher than 240 °F (115 °C). The temperature difference specified in the table is to be taken into account when determining the viscosity in the bearing.

If the above conditions cannot be maintained due to extreme operating parameters, we recommend flushing the case at port **U** or using a flushing and boost pressure valve (see page 63).

Viscosity and temperature of hydraulic fluids

	Viscosity	Temperature	Comment
Cold start	$\nu_{max} \leq 7400$ SUS (1600 mm ² /s)	$\theta_{St} \geq -40$ °F (-40 °C)	$t \leq 3$ min, $n \leq 1000$ rpm, without load $p \leq 725$ psi ($p \leq 50$ bar)
Permissible temperature difference		$\Delta T \leq 45$ °F (25 K)	between axial piston unit and hydraulic fluid in the system
Warm-up phase	$\nu < 7400$ to 1850 SUS (1600 to 400 mm ² /s)	$\theta = -40$ °F to -13 °F (-40 °C to -25 °C)	at $p \leq 0.7 \times p_{nom}$, $n \leq 0.5 \times n_{nom}$ and $t \leq 15$ min
Continuous operation	$\nu = 1850$ to 47 SUS (400 to 10 mm ² /s)	$\theta = -13$ °F to +217 °F (-25 °C to +103 °C)	This corresponds, for example on the VG 46, to a temperature range of +41 °F to + 185 °F (+5 °C to +85 °C)(see selection diagram) measured at port T Note the permissible temperature range of the shaft seal ($\Delta T =$ approx. 22 °F (12 K) between the bearing/shaft seal and port T)
		$\nu_{opt} = 167$ to 81 SUS (36 to 16 mm ² /s)	Range of optimum operating viscosity and efficiency
Short-term operation	$\nu_{min} \geq 49$ SUS (7 mm ² /s)		$t < 3$ min, $p < 0.3 \times p_{nom}$

▼ Selection diagram

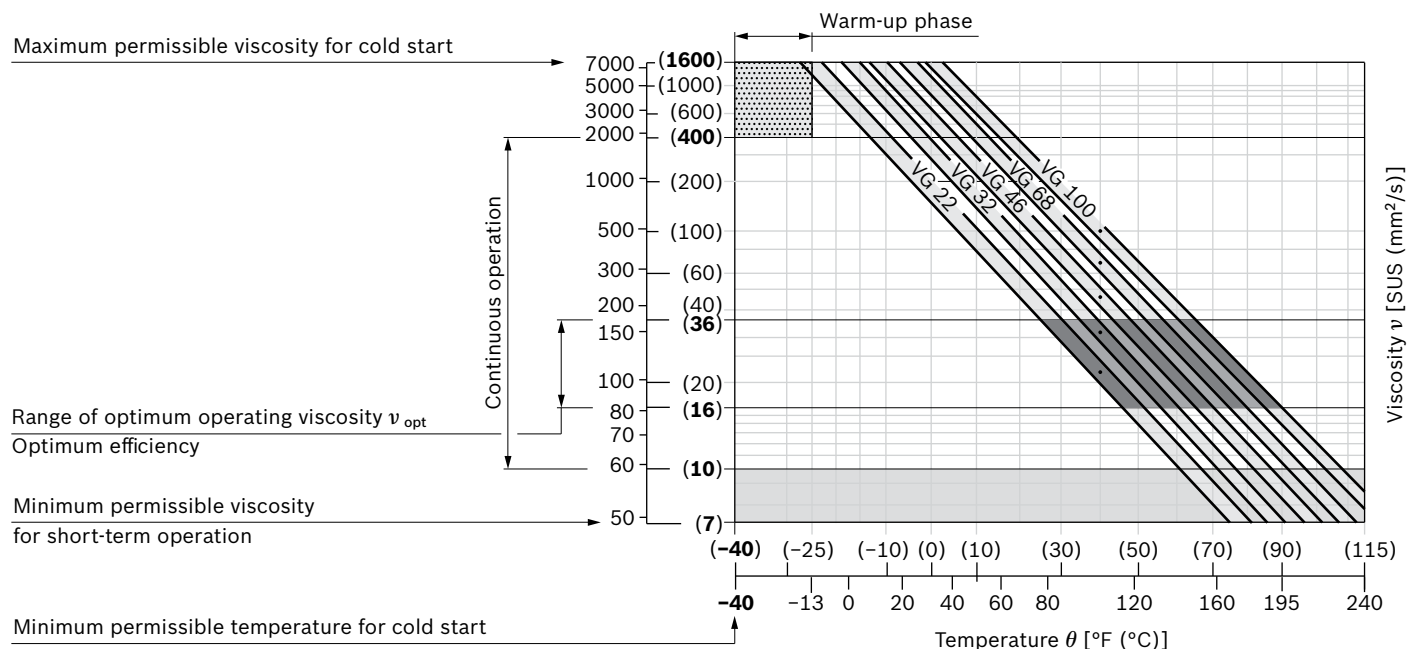

Filtration of the hydraulic fluid

Finer filtration improves the cleanliness level of the hydraulic fluid, which increases the service life of the axial piston unit.

A cleanliness level of at least 20/18/15 is to be maintained according to ISO 4406.

At very high hydraulic fluid temperatures (195 °F (90 °C) to maximum 217 °F (103 °C), measured at port **T**), a cleanliness level of at least 19/17/14 according to ISO 4406 is necessary.

Influence of case pressure on beginning of control

An increase in case pressure affects the beginning of control when using the following control options:

- ▶ HP, HA.T3: Increase
- ▶ DA: Decrease

With the following settings, an increase in case pressure will have no effect on the beginning of control:

HA.R and HA.U, EP, HA

The factory setting of the beginning of control is made at $p_{abs} = 30 \text{ psi (2 bar)}$ case pressure.

Flow direction

Direction of rotation, viewed on drive shaft	
clockwise (cw)	counter-clockwise (ccw)
A to B	B to A

Shaft seal

Permissible pressure loading

The service life of the shaft seal will be influenced by the speed of the axial piston unit and the leakage pressure in the housing (case pressure). Momentary pressure spikes ($t < 0.1 \text{ s}$) of up to 145 psi (10 bar) are permitted. The service life of the shaft seal decreases with increasing frequency of pressure spikes and increasing mean differential pressure.

The case pressure must be equal to or higher than the ambient pressure.

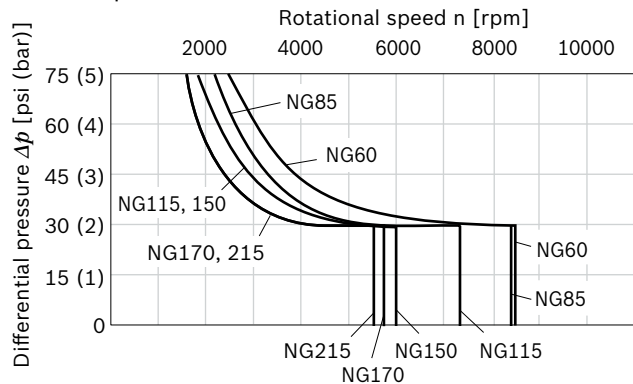

The FKM shaft seal may be used for leakage temperatures from -13 °F to +240 °F (-25 °C to +115 °C). For application cases below -13 °F (-25 °C), an NBR shaft seal is required (permissible temperature range: -40 °F to +195 °F (-40 °C to +90 °C)).

Operating pressure range

Pressure at working port A or B		Definition
Nominal pressure p_{nom}	6500 psi (450 bar)	The nominal pressure corresponds to the maximum design pressure.
Maximum pressure p_{max}	7250 psi (500 bar)	The maximum pressure corresponds to the maximum operating pressure within the single operating period. The sum of the single operating periods must not exceed the total operating period.
Single operating period	10 s	
Total operating period	300 h	
Minimum pressure (high-pressure side)	365 psi (25 bar)	Minimum pressure at the high-pressure side (A or B) which is required in order to prevent damage to the axial piston unit.
Minimum pressure – pump operating mode (inlet)	See the diagram below	To prevent damage to the axial piston motor in pump operating mode (change of high-pressure side with unchanged direction of rotation, e. g. when braking), a minimum pressure must be guaranteed at working port (inlet). This minimum pressure is dependent on the speed and displacement of the axial piston unit (see characteristic curve)
Summation pressure p_{Su} (pressure A + pressure B)	10150 psi (700 bar)	The summation pressure is the sum of the pressures at both working ports (A and B)
Rate of pressure change $R_{A\ max}$		Maximum permissible rate of pressure build-up and reduction during a pressure change over the entire pressure range.
With integrated pressure-relief valve	130530 psi/s (9000 bar/s)	
Without pressure-relief valve	232060 psi/s (16000 bar/s)	

▼ Rate of pressure change $R_{A\ max}$

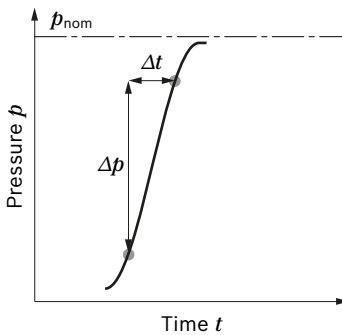

▼ Pressure definition

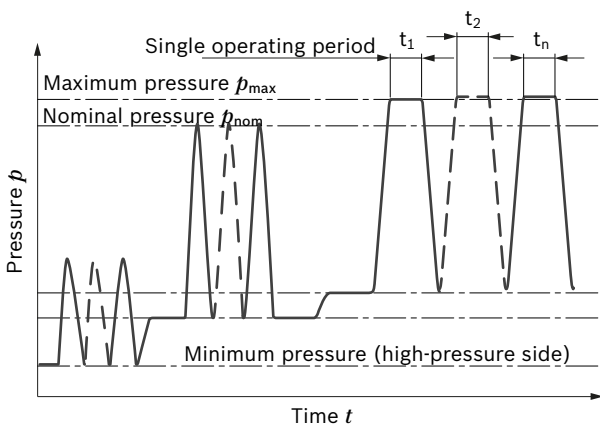

Total operating period = $t_1 + t_2 + \dots + t_n$

▼ Minimum pressure – pump operating mode (inlet)

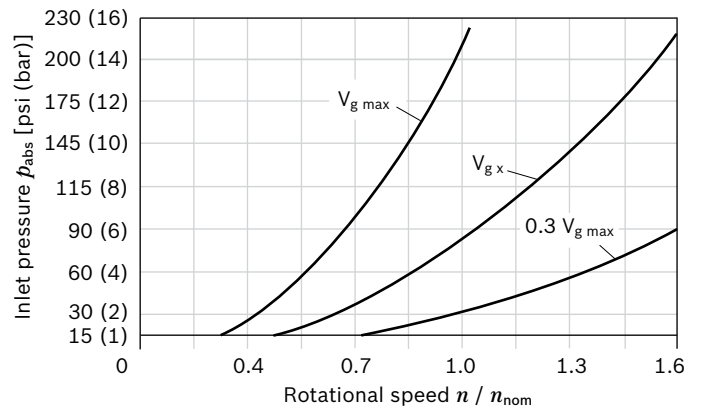

This diagram is valid only for the optimum viscosity range from $\nu_{opt} = 170$ to 73 SUS (36 to 16 mm²/s).

Please contact us if these conditions cannot be satisfied.

Note

Operating pressure range valid when using hydraulic fluids based on mineral oils. Values for other hydraulic fluids, please contact us.

Technical data

Size	NG	60	85	115	160	170	215		
Displacement geometric, per revolution	$V_{g \max}$	in ³	3.78	5.20	7.05	9.28	10.48	13.21	
		cm ³	62.0	85.2	115.6	152.1	171.8	216.5	
	$V_{g \min}$	in ³	0	0	0	0	0	0	
		cm ³	0	0	0	0	0	0	
	$V_{g x}$	in ³	2.26	3.11	4.21	5.55	3.97	5.00	
		cm ³	37	51	69	91	65	82	
Maximum speed ¹⁾ (complying with the maximum permissible inlet flow)	at $V_{g \max}$	n_{nom}	rpm	4450	3900	3550	3250	3100	2900
	at $V_g < V_{g x}$ (see diagram)	n_{max}	rpm	7200	6800	6150	5600	4900	4800
	at $V_{g 0}$	n_{max}	rpm	8400	8350	7350	6000	5750	5500
Inlet flow ²⁾	at n_{nom} and $V_{g \max}$	$q_{v \max}$	gpm	73	88	108	131	141	166
			l/min	276	332	410	494	533	628
Torque ³⁾	at $V_{g \max}$ and $\Delta p = 6500$ psi (450 bar)	T	lb-ft	326	448	608	800	903	1139
			Nm	444	610	828	1089	1230	1550
Rotary stiffness	$V_{g \max}$ to $V_g/2$	c_{\min}	lb-ft/rad	10695	16521	27511	32084	38279	51334
			kNm/rad	14500	22400	37300	43500	51900	69600
	$V_g/2$ to 0 (interpolated)	c_{\min}	lb-ft/rad	33412	49785	76559	91458	115355	144267
			kNm/rad	45300	67500	103800	124000	156400	195600
Moment of inertia for rotary group	J_{TW}	lb-ft ²	0.1020	0.1709	0.2610	0.4295	0.5055	0.7190	
		kgm ²	0.0043	0.0072	0.0110	0.0181	0.0213	0.0303	
Maximum angular acceleration	α	rad/s ²	21000	17500	15500	11000	11000	10000	
Case volume	V	gal	0.21	0.26	0.40	0.45	0.61	0.74	
		l	0.8	1.0	1.5	1.7	2.3	2.8	
Weight, approx.	m	lbs	62	79	101	134	137	172	
		kg	28	36	46	61	62	78	

▼ Permissible displacement in relation to speed

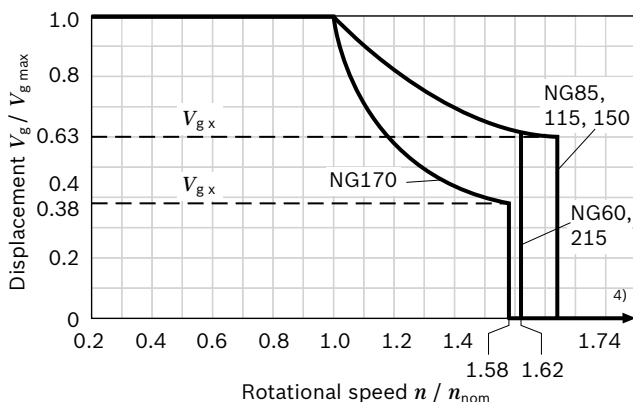

Notes

- ▶ Theoretical values, without efficiency levels and tolerances; values rounded
- ▶ Operation above the maximum values or below the minimum values may result in a loss of function, a reduced service life or in the destruction of the axial piston unit. Other permissible limit values, such as speed variation, reduced angular acceleration as a function of the frequency and the permissible angular acceleration at start (lower than the maximum angular acceleration) can be found in data sheet 90261.

Determining the operating characteristics

Inlet flow	$q_v = \frac{V_g \times n}{231 \times \eta_v}$ [gpm]	$\left(\frac{V_g \times n}{1000 \times \eta_v} \right)$ [l/min]
Rotational speed	$n = \frac{q_v \times 231 \times \eta_v}{V_g}$ [rpm]	$\left(\frac{q_v \times 1000 \times \eta_v}{V_g} \right)$ [rpm]
Torque	$T = \frac{V_g \times \Delta p \times \eta_{mh}}{24 \times \pi}$ [lb-ft]	$\left(\frac{V_g \times \Delta p \times \eta_{mh}}{20 \times \pi} \right)$ [Nm]
Power	$P = \frac{2 \pi \times T \times n}{33000} = \frac{q_v \times \Delta p \times \eta_t}{1714}$ [HP]	$\left(\frac{2 \pi \times T \times n}{60000} = \frac{q_v \times \Delta p \times \eta_t}{600} \right)$ [kW]

Key

- V_g = Displacement per revolution [in³ (cm³)]
- Δp = Differential pressure [psi (bar)]
- n = Rotational speed [rpm]
- η_v = Volumetric efficiency
- η_{mh} = Mechanical-hydraulic efficiency
- η_t = Total efficiency ($\eta_t = \eta_v \cdot \eta_{mh}$)

- The values are valid:
 - For the optimum viscosity range from $\nu_{\text{opt}} = 170$ to 75 SUS (36 to 16 mm²/s)
 - with hydraulic fluid on the basis of mineral oil
- Note inlet flow limitation due to counterbalance valve (see page 65).
- Torque without radial force, With radial force see page 9.
- Values in this range on request

Permissible radial and axial forces of the drive shafts

Size	NG		60	85	115	150	150	170	215
Drive shaft		in	1 1/4	1 1/2	1 3/4	1 3/4	2	2	2
Maximum radial force ¹⁾ at distance a (from shaft collar)	$F_{q \max}$	lb	1713	2802	3350	3585	3917	4355	5081
		N	7620	12463	14902	15948	17424	19370	22602
	a	in	0.94	1.06	1.32	1.32	1.32	1.32	1.32
		mm	24.0	27.0	33.5	33.5	33.5	33.5	33.5
Torque maximum at $F_{q \max}$	T_{\max}	lb-ft	229	439	611	656	803	679	939
		Nm	310	595	828	890	1089	1230	1445
Differential pressure maximum at $V_{g \max}$ and $F_{q \max}$	Δp_{\max}	psi	4550	6400	6500	5350	6500	6500	6100
		bar	315	440	450	370	450	450	420
Maximum axial force, at standstill or pressure-free operation	$+ F_{ax \max}$	lb	0	0	0	0	0	0	0
		N	0	0	0	0	0	0	0
	$- F_{ax \max}$	lb	112	160	202	232	232	252	281
		N	500	710	900	1030	1030	1120	1250
Permissible axial force per psi (bar) operating pressure	$+ F_{ax \text{ perm}/\text{bar}}$	lb/psi	0.12	0.15	0.18	0.21	0.21	0.23	0.26
		N/bar	7.5	9.6	11.3	13.3	13.3	15.1	17.0

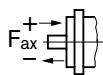
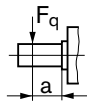

Effect of radial force F_q on the service life of bearings

By selecting a suitable direction of radial force F_q , the load on the bearings, caused by the internal rotary group forces can be reduced, thus optimizing the service life of the bearings. Recommended position of mating gear is dependent on direction of rotation. Examples:

Notes

- ▶ The values given are maximum values and do not apply to continuous operation.
- ▶ The permissible axial force in $-F_{ax}$ direction is to be avoided, because thereby the bearing life is reduced.
- ▶ Special requirements apply in the case of belt drives. Please contact us.

▼ Toothed gear output drive

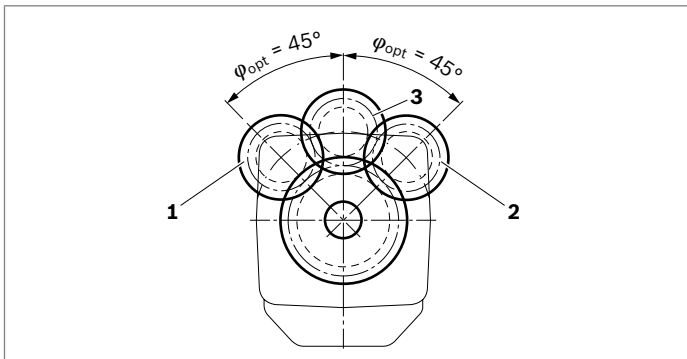

- 1** Direction of rotation "counter-clockwise", pressure at port **B**
- 2** Direction of rotation "clockwise", pressure at port **A**
- 3** Bidirectional direction of rotation

1) With intermittent operation

HP – Proportional hydraulic control

The proportional hydraulic control provides infinite adjustment of the displacement. The control is proportional to the pilot pressure applied to port **X**.

HP1, HP2 positive control

- ▶ Beginning of control at $V_{g \min}$ (minimum torque, maximum permissible speed at minimum pilot pressure)
- ▶ End of control at $V_{g \max}$ (maximum torque, minimum speed at maximum pilot pressure)

HP5, HP6 negative control

- ▶ Beginning of control at $V_{g \max}$ (maximum torque, minimum speed at minimum pilot pressure)
- ▶ End of control at $V_{g \min}$ (minimum torque, maximum permissible speed at maximum pilot pressure)

Note

- ▶ Maximum permissible pilot pressure: $p_{St} = 1450 \text{ psi (100 bar)}$
- ▶ The control oil is internally taken from the high pressure side of the motor (**A** or **B**). For reliable control, an operating pressure of at least 435 psi (30 bar) is required in **A** (**B**). If a control operation is performed at an operating pressure < 435 psi (30 bar), an auxiliary pressure of at least 435 psi (30 bar) must be applied at port **G** via an external check valve. For lower pressures, please contact us.
Please note that pressures up to 7250 psi (500 bar) can occur at port **G**.
- ▶ Please state the desired beginning of control in plain text when ordering, e. g.: beginning of control at 145 psi (10 bar).
- ▶ The beginning of control and the HP characteristic curve are influenced by the case pressure. An increase in case pressure causes an increase in the beginning of control (see page 6) and thus a parallel displacement of the characteristic.
- ▶ A leakage flow of maximum 0.08 gpm (0.3 l/min) can escape at port **X** due to internal leakage (operating pressure > pilot pressure). The control is to be suitably configured to avoid an independent build-up of pilot pressure.

Response time damping

The response time damping is influencing the stroke characteristics of the motor and thus the reaction speed of the machine.

Standard with Size 60 to 215

HP without damping.

HP.D with throttle pin on both sides, symmetrical (as to table)

Option with Size 60 to 215

HP with throttle pin on both sides, symmetrical (as to table)

▼ Overview Throttle Pins

Size		60	85	115	150	170	215
Groove size	[inch]	0.018	0.018	0.022	0.022	0.022	0.026
	[mm]	0.45	0.45	0.55	0.55	0.55	0.65

HP1, HP5 pilot pressure increase $\Delta p_{St} = 145 \text{ psi (10 bar)}$

HP1 positive control

A pilot pressure increase of 145 psi (10 bar) at port **X** results in an increase in displacement from $V_{g \min}$ to $V_{g \max}$.

HP5 negative control

A pilot pressure increase of 145 psi (10 bar) at port **X** results in a decrease in displacement from $V_{g \max}$ to $V_{g \min}$.

- ▶ Beginning of control, setting range 30 to 290 psi (2 to 20 bar)
- ▶ Standard setting:
Beginning of control at 45 psi (3 bar) (end of control at 190 psi (13 bar))

▼ Characteristic curve

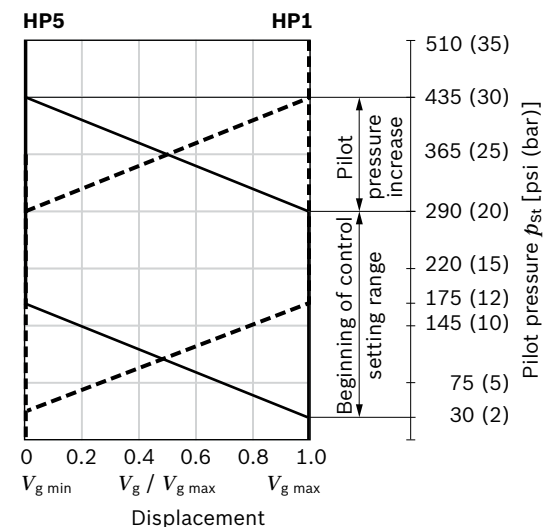

HP2, HP6 pilot pressure increase $\Delta p_{st} = 365 \text{ psi (25 bar)}$

HP2 positive control

A pilot pressure increase of 365 psi (25 bar) at port **X** results in an increase in displacement from $V_{g \text{ min}}$ to $V_{g \text{ max}}$.

HP6 negative control

A pilot pressure increase of 365 psi (25 bar) at port **X** results in a decrease in displacement from $V_{g \text{ max}}$ to $V_{g \text{ min}}$.

- ▶ Beginning of control, setting range 75 to 725 psi (5 to 50 bar)
- ▶ Standard setting:
 Beginning of control at 145 psi (10 bar) (end of control at 510 psi (35 bar))

▼ **Characteristic curve**

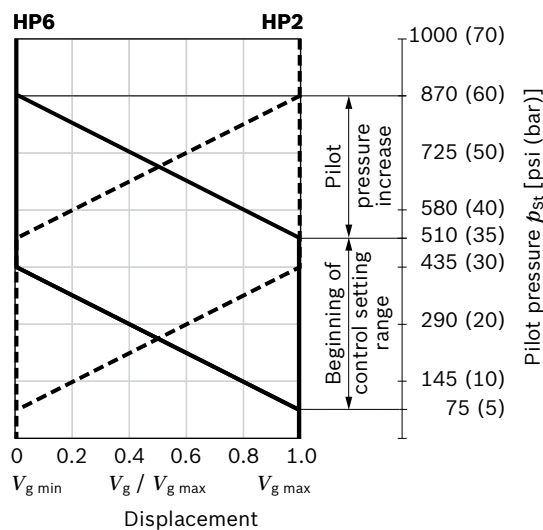

▼ **Circuit diagram HP5, HP6 (negative control)**

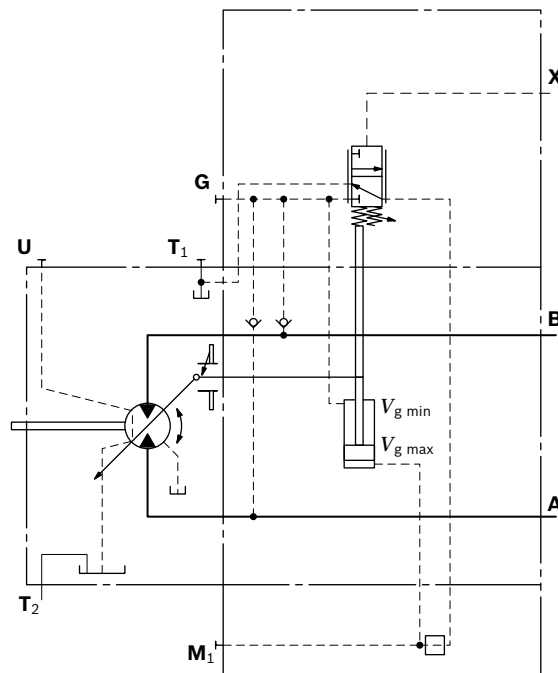

▼ **Circuit diagram HP1, HP2 (positive control)**

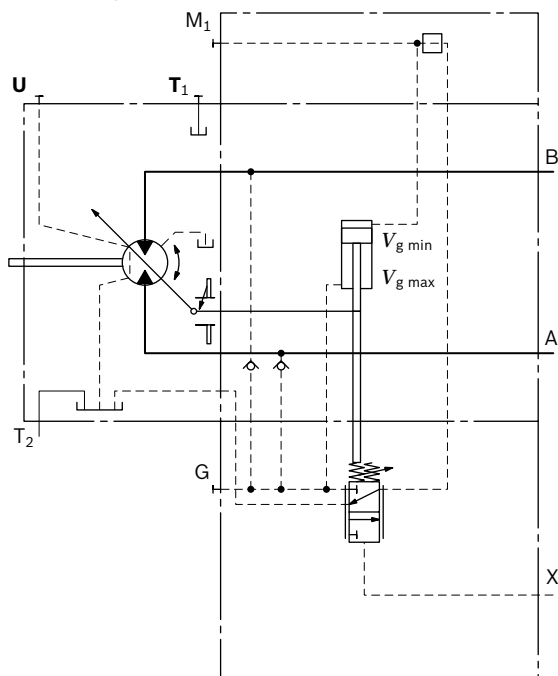

HP5D1, HP6D1 Pressure control, fixed setting

The pressure control overrides the HP control function.

If the load torque or a reduction in motor swivel angle causes the system pressure to reach the setpoint value of the pressure control, the motor will swivel towards a larger displacement.

The increase in the displacement and the resulting reduction in pressure cause the control deviation to decrease.

With the increase in displacement the motor develops more torque, while the pressure remains constant.

Setting range of the pressure control valve 1150 to 6500 psi
(80 to 450 bar)

▼ Circuit diagram HP5D1, HP6D1 (negative control)

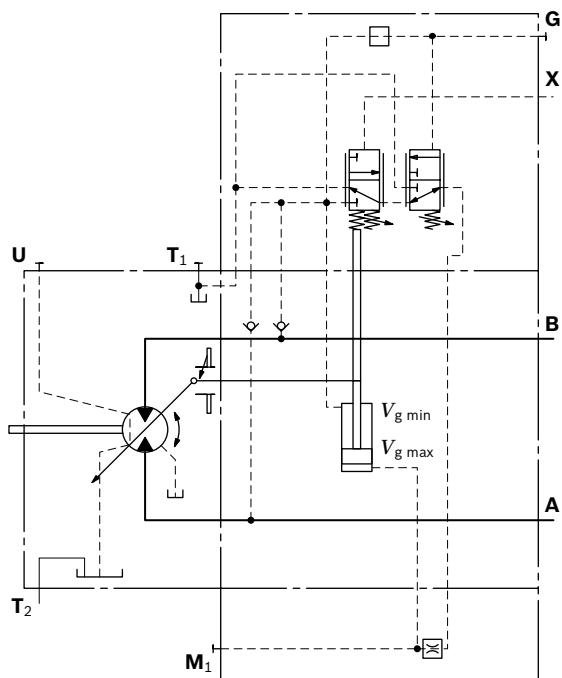

EP – Proportional electric control

The proportional electric control provides infinite setting of the displacement. Control is proportional to the electric control current applied to the solenoid.

EP1, EP2 positive control

- ▶ Beginning of control at $V_{g \min}$ (minimum torque, maximum permissible speed at minimum control current)
- ▶ End of control at $V_{g \max}$ (maximum torque, minimum speed at maximum control current)

EP5, EP6 negative control

- ▶ Beginning of control at $V_{g \max}$ (maximum torque, minimum speed at minimum control current)
- ▶ End of control at $V_{g \min}$ (minimum torque, maximum permissible speed at maximum control current)

▼ Characteristic curve

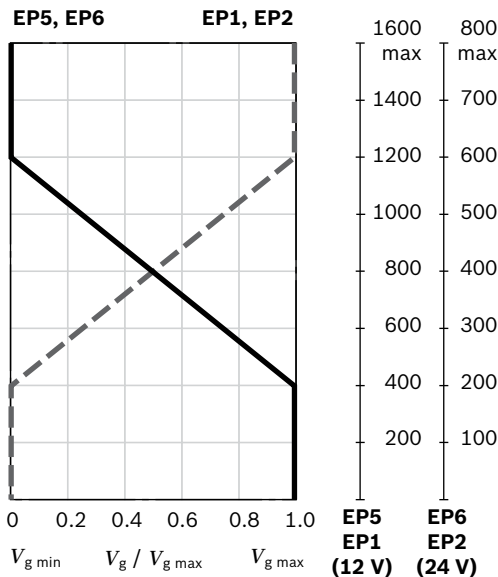

Note

The control oil is internally taken out of the high pressure side of the motor (**A** or **B**). For reliable control, an operating pressure of at least 435 psi (30 bar) is necessary in **A** (**B**). If a control operation is performed at an operating pressure < 435 psi (30 bar), an auxiliary pressure of at least 435 psi (30 bar) must be applied at port **G** using an external check valve. For lower pressures, please contact us. Please note that pressures up to 7250 psi (500 bar) can occur at port **G**.

Response time damping

The response time damping is influencing the stroke characteristics of the motor and thus the reaction speed of the machine.

Standard with Size 60 to 215

EP without damping.

EP.D with throttle pin on both sides, symmetrical (as to table)

Option with Size 60 to 115

EP with throttle pin on both sides, symmetrical (as to table)

▼ Overview Throttle Pins

Size	60	85	115	150	170	215
Groove size	[inch] 0.018	0.018	0.022	0.022	0.022	0.026
	[mm] 0.45	0.45	0.55	0.55	0.55	0.65

Technical data, solenoid	EP1, EP5	EP2, EP6
Voltage	12 V (±20 %)	24 V (±20 %)
Control current		
Beginning of control	400 mA	200 mA
End of control	1200 mA	600 mA
Current limit	1.54 A	0.77 A
Nominal resistance (at 68 °F (20 °C))	5.5 Ω	22.7 Ω
Dither frequency	100 Hz	100 Hz
Duty cycle	100 %	100 %
Type of protection: see connector version on page 62		

Various BODAS controllers with application software and amplifiers are available for controlling the proportional solenoids.

Further information can also be found on the internet at www.boschrexroth.com/mobile-electronics.

▼ **Circuit diagram EP1, EP2 (positive control)**

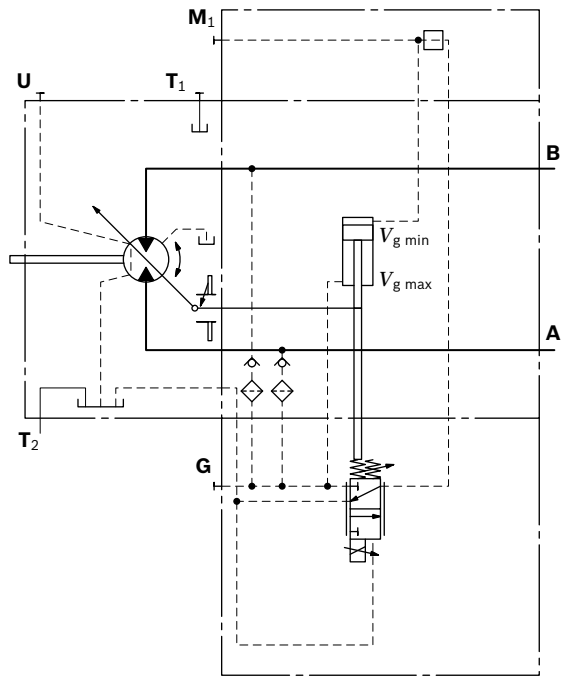

▼ **Circuit diagram EP5, EP6 (negative control)**

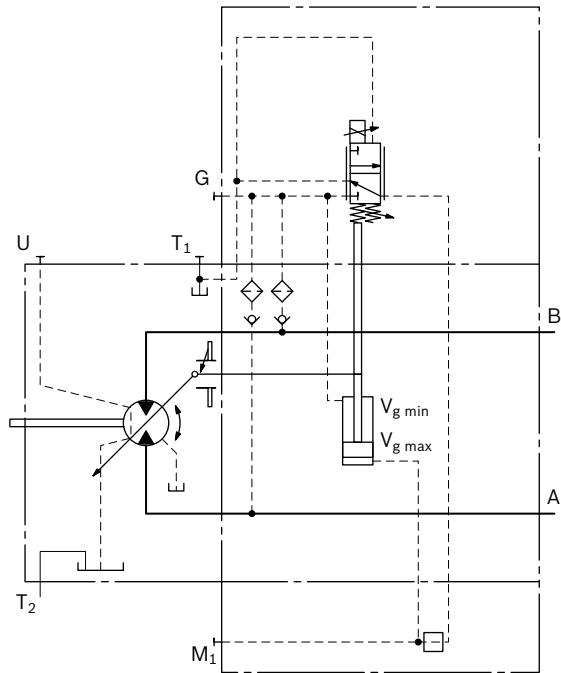

▼ **EP5D1, EP6D1 Pressure control, fixed setting**

The pressure control overrides the EP control function. If the load torque or a reduction in motor swivel angle causes the system pressure to reach the setpoint value of the pressure control, the motor will swivel towards a larger displacement.

The increase in the displacement and the resulting reduction in pressure cause the control deviation to decrease. With the increase in displacement the motor develops more torque, while the pressure remains constant.

Setting range of the pressure control valve 1150 to 6500 psi (80 to 450 bar)

▼ **Circuit diagram EP5D1, EP6D1 (negative control)**

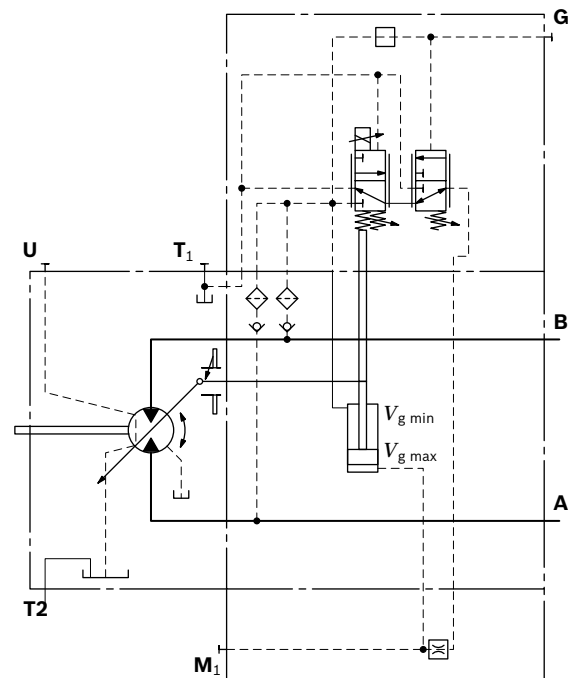

HZ – Two-point hydraulic control

The two-point hydraulic control allows the displacement to be set to either $V_{g\ min}$ or $V_{g\ max}$ by switching the pilot pressure at port **X** on or off.

HZ5, HZ7 negative control

- ▶ Position at $V_{g\ max}$ (without pilot pressure, maximum torque, minimum speed)
- ▶ Position at $V_{g\ min}$ (with pilot pressure > 145 psi (10 bar) activated, minimum torque, maximum permissible speed)

▼ Characteristic curve HZ5, HZ7

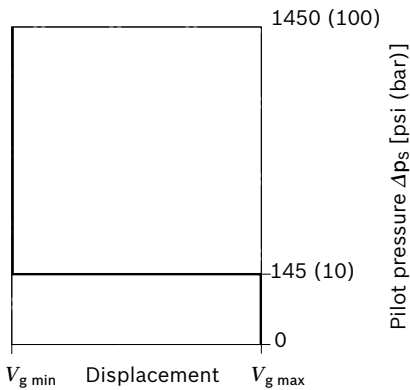

Note

- ▶ Maximum permissible pilot pressure: 1450 psi (100 bar)
- ▶ The control oil is internally taken out of the high pressure side of the motor (**A** or **B**). For reliable control, an operating pressure of at least 435 psi (30 bar) is required in **A** (**B**). If a control operation is performed at an operating pressure < 435 psi (30 bar), an auxiliary pressure of at least 435 psi (30 bar) must be applied at port **G** via an external check valve. For lower pressures, please contact us. Please note that pressures up to 7250 psi (500 bar) can occur at port **G**.

Response time damping

The response time damping is influencing the stroke characteristics of the motor and thus the reaction speed of the machine.

Standard with Size 150 to 215

HZ5 with throttle pin on both sides, symmetrical (as to table)

Standard with Size 60 to 115

HZ7 (Synchronizing piston) with throttle pin on both sides, symmetrical (as to table)

▼ Overview Throttle Pins

Size	60	85	115	150	170	215	
Groove	[inch]	0.012	0.012	0.012	0.022	0.022	0.026
size	[mm]	0.30	0.30	0.30	0.55	0.55	0.65

▼ Circuit diagram HZ5 (negative control) size 150 to 215

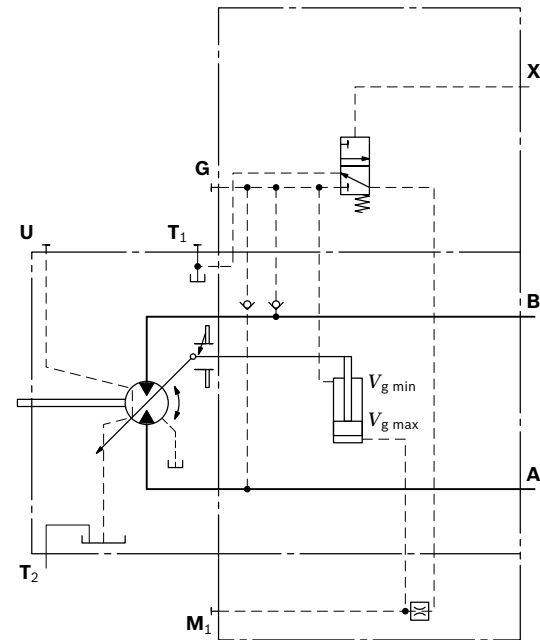

▼ Circuit diagram HZ7 (negative control) size 60 to 115

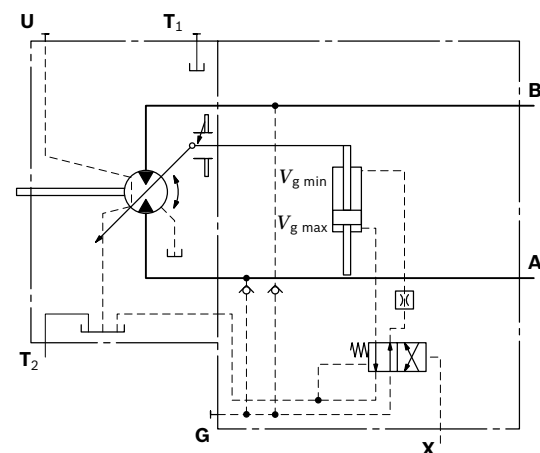

EZ – Two-point electric control

The two-point electric control allows the displacement to be set to either $V_{g \min}$ or $V_{g \max}$ by switching the electric current to a switching solenoid on or off.

Note

The control oil is internally taken out of the high pressure side of the motor (**A** or **B**). For reliable control, an operating pressure of at least 435 psi (30 bar) is required in **A** (**B**). If a control operation is performed at an operating pressure < 435 psi (30 bar), an auxiliary pressure of at least 435 psi (30 bar) must be applied at port **G** via an external check valve. For lower pressures, please contact us. Please note that pressures up to 7250 psi (500 bar) can occur at port **G**.

Response time damping

The response time damping is influencing the stroke characteristics of the motor and thus the reaction speed of the machine.

Standard with Size 150 to 215

EZ5, EZ6 with throttle pin on both sides, symmetrical (as to table)

Option with Size 60 to 115

EZ7, EZ8 (Synchronizing piston) with throttle pin on both sides, symmetrical (as to table)

▼ Overview Throttle Pins

Size	60	85	115	150	170	215
Groove size	[inch] 0.012	0.012	0.012	0.022	0.022	0.026
	[mm] 0.30	0.30	0.30	0.55	0.55	0.65

Sizes 150 to 215

Technical data, solenoid with DIA37	EZ5	EZ6
Voltage	12 V (±20 %)	24 V (±20 %)
Position $V_{g \max}$	de-energized	de-energized
Position $V_{g \min}$	energized	energized
Nominal resistance (at 68 °F (20 °C))	5.5 Ω	21.7 Ω
Nominal power	26.2 W	26.5 W
Minimum required active current	1.32 A	0.67 A
Duty cycle	100 %	100 %
Type of protection: see connector version on page 62		

▼ Circuit diagram EZ5, EZ6 (negative control) size 150 to 215

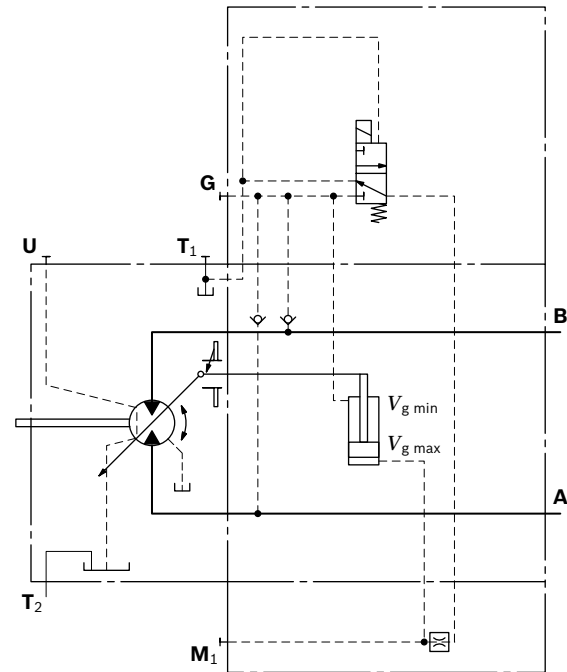

Sizes 60 to 115

Technical data, solenoid with DIA45	EZ7	EZ8
Voltage	12 V (±20 %)	24 V (±20 %)
Position $V_{g \max}$	de-energized	de-energized
Position $V_{g \min}$	energized	energized
Nominal resistance (at 68 °F (20 °C))	4.8 Ω	19.2 Ω
Nominal power	30 W	30 W
Minimum required active current	1.5 A	0.75 A
Duty cycle	100 %	100 %
Type of protection: see connector version on page 62		

▼ Circuit diagram EZ7, EZ8 (negative control) size 60 to 115

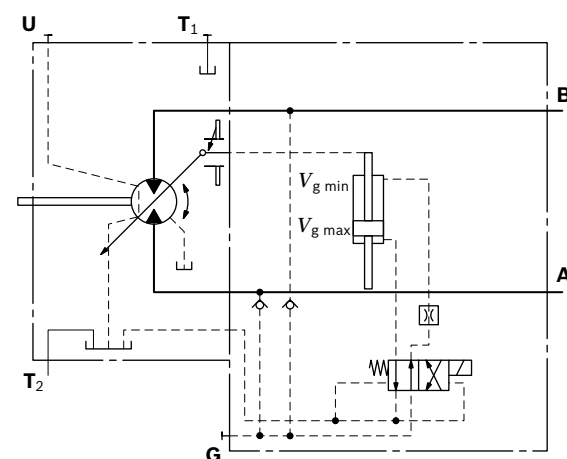

HA – Automatic high-pressure related control

The automatic high-pressure related control adjusts the displacement automatically depending on the operating pressure.

The displacement of the A6VM motor with HA control is $V_{g\ min}$ (maximum speed and minimum torque). The control unit internally measures the operating pressure at **A** or **B** (no control line required) and upon reaching the set beginning of control, the controller swivels the motor from $V_{g\ min}$ to $V_{g\ max}$ with increase of operating pressure. The displacement is modulated between $V_{g\ min}$ and $V_{g\ max}$, thereby depending on load conditions.

HA1, HA2 positive control

- ▶ Beginning of control at $V_{g\ min}$ (minimum torque, maximum speed)
- ▶ End of control at $V_{g\ max}$ (maximum torque, minimum speed)

Note

- ▶ For safety reasons, winch drives are not permissible with beginning of control at $V_{g\ min}$ (standard for HA).
- ▶ The control oil is internally taken out of the high pressure side of the motor (**A** or **B**). For reliable control, an operating pressure of at least 435 psi (30 bar) is required in **A** (**B**). If a control operation is performed at an operating pressure < 435 psi (30 bar), an auxiliary pressure of at least 435 psi (30 bar) must be applied at port **G** via an external check valve. For lower pressures, please contact us.
Please note that pressures up to 7250 psi (500 bar) can occur at port **G**.
- ▶ The beginning of control and the HA.T3 characteristic curve are influenced by case pressure. An increase in case pressure causes an increase in the beginning of control (see page 6) and thus a parallel shift of the characteristic.

Response time damping

The response time damping is influencing the stroke characteristics of the motor and thus the reaction speed of the machine.

Standard with Size 60 to 215

HA1,2 with one-sided throttle pin, the throttling occurs from $V_{g\ min}$ to $V_{g\ max}$. (as to table)

▼ Overview Throttle Pins

Size		60	85	115	150	170	215
Groove size	[inch]	0.018	0.018	0.022	0.022	0.022	0.022
	[mm]	0.45	0.45	0.55	0.55	0.55	0.65

Standard with Size 60 to 215

HA1, 2 with one sided throttle pin effects the stroking time of the motor from $V_{g\ min}$ to $V_{g\ max}$. (as to table)

▼ Overview Throttle Screw

Size		60	85	115	150	170	215
Groove size	[inch]	0.031	0.031	0.031	0.031	0.031	0.031
	[mm]	0.80	0.80	0.80	0.80	0.80	0.80

HA1 with minimum pressure increase, positive control

An operating pressure increase of $\Delta p \leq$ approx. 145 psi (10 bar) results in an increase in displacement from $V_{g \min}$ towards $V_{g \max}$.

Beginning of control, setting range 1150 to 5100 psi (80 to 350 bar)

Please state the desired beginning of control in plain text when ordering, e. g.: beginning of control at 4350 psi (300 bar).

▼ **Characteristic curve HA1**

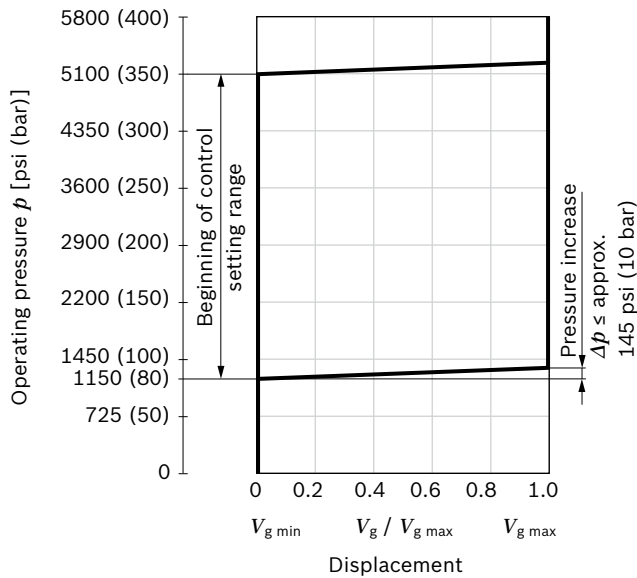

HA2 with pressure increase, positive control

An operating pressure increase of $\Delta p \leq$ approx. 1450 psi (100 bar) results in an increase in displacement from $V_{g \min}$ to $V_{g \max}$.

Beginning of control, setting range 1150 to 5100 psi (80 to 350 bar)

Please state the desired beginning of control in plain text when ordering, e. g.: beginning of control at 2900 psi (200 bar)

▼ **Characteristic curve HA2**

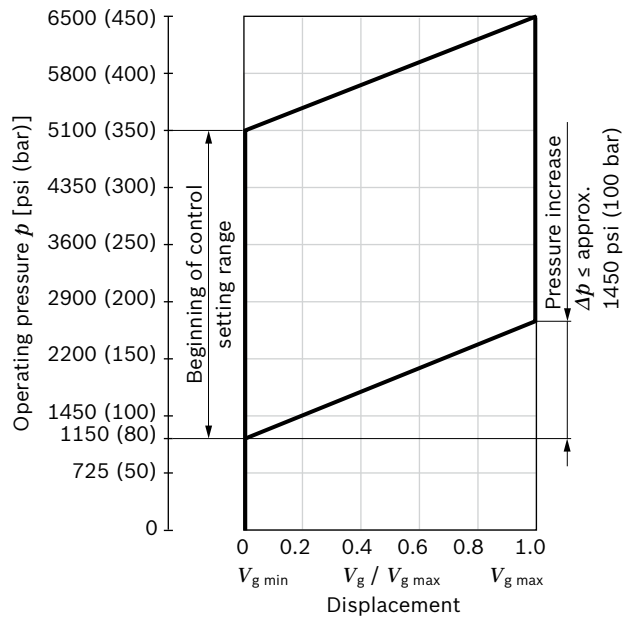

▼ **Circuit diagram HA1**

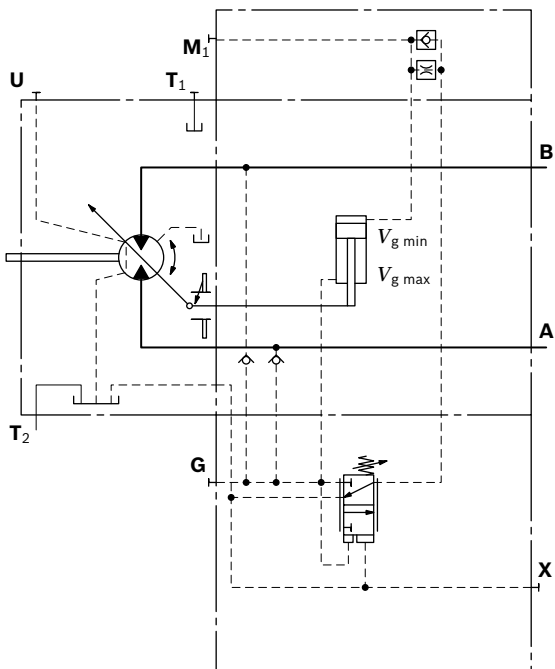

▼ **Circuit diagram HA2**

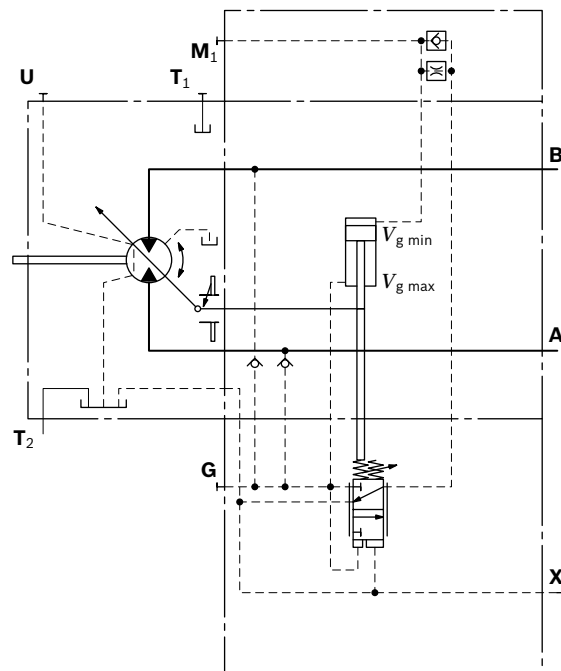

HA.T3 hydraulic override, remote control, proportional

With the HA.T3 control, the beginning of control can be influenced by applying a pilot pressure to port **X**.

For each 15 psi (1 bar) of pilot pressure increase, the beginning of control is reduced by 250 psi (17 bar).

Beginning of control setting	4350 psi (300 bar)	4350 psi (300 bar)
Pilot pressure at port X	0 psi 0 bar	145 psi (10 bar)
Beginning of control at	4350 psi (300 bar)	1900 psi (130 bar)

Note

Maximum permissible pilot pressure 1450 psi (100 bar).

▼ **Circuit diagram HA1.T3**

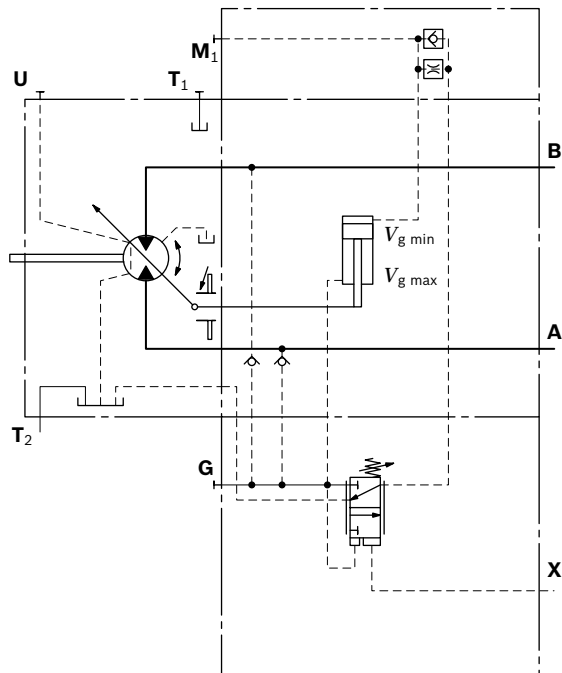

▼ **Circuit diagram HA2.T3**

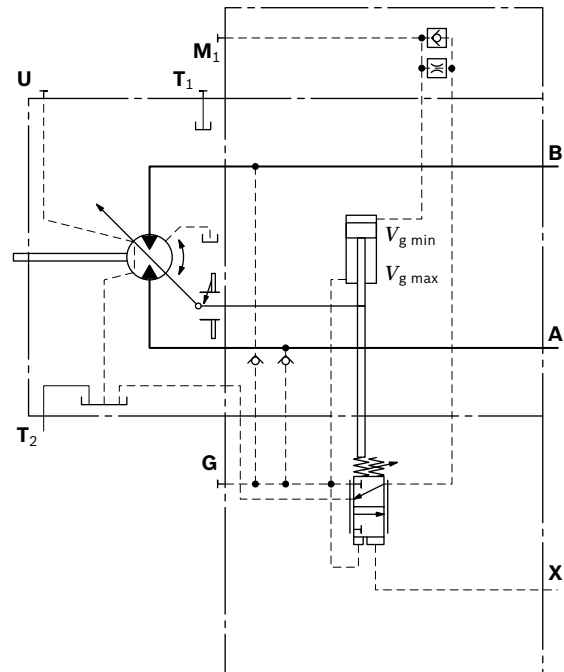

HA.U1, HA.U2 electric override, two-point

With the HA.U1 or HA.U2 control, the beginning of control can be overridden by an electric signal to a switching solenoid. When the override solenoid is energized, the variable motor swivels to maximum swivel angle, without intermediate position.

The beginning of control can be set between 1150 and 4350 psi (80 and 300 bar) (specify required setting in plain text when ordering).

Technical data, solenoid with DIA45	U1	U2
Voltage	12 V ($\pm 20\%$)	24 V ($\pm 20\%$)
No override	de-energized	de-energized
Position $V_{g \max}$	energized	energized
Nominal resistance (at 68 °F (20 °C))	4.8 Ω	19.2 Ω
Nominal power	30 W	30 W
Minimum required active current	1.5 A	0.75 A
Duty cycle	100 %	100 %
Type of protection: see connector version on page 62		

▼ **Circuit diagram HA2U1, HA2U2**

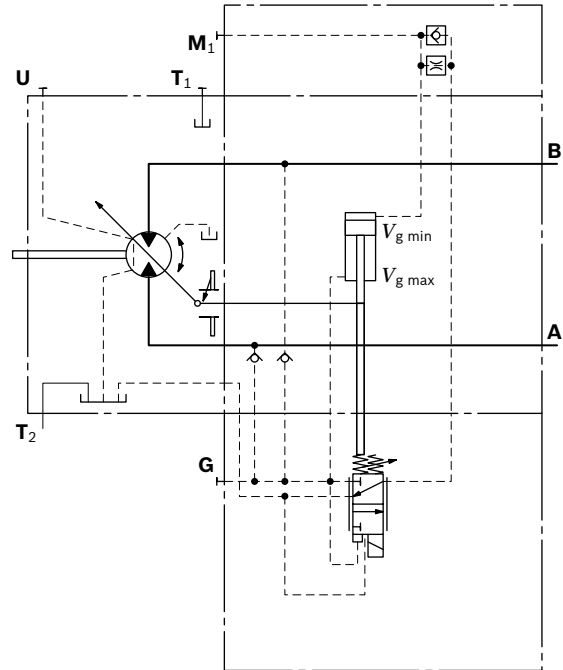

▼ **Circuit diagram HA1U1, HA1U2**

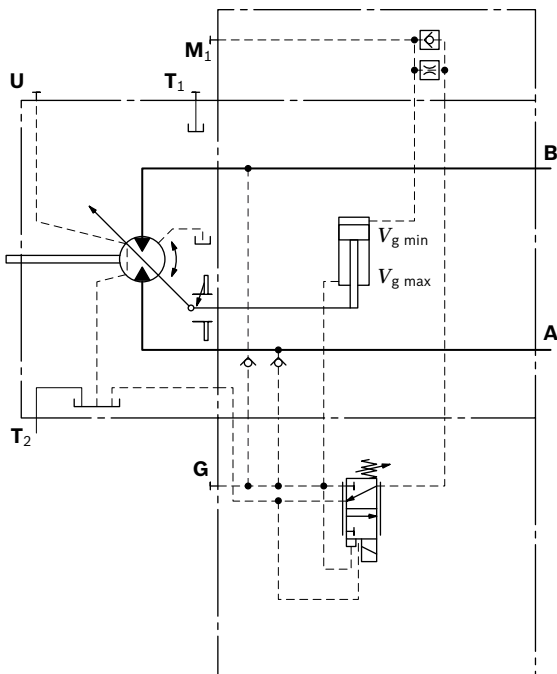

HA.R1, HA.R2 electric override, electric travel direction valve

With the HA.R1 or HA.R2 control, the beginning of control can be overridden by an electric signal to switching solenoid **b**. When the override solenoid is energized, the variable motor swivels to maximum swivel angle, without intermediate position.

The travel direction valve ensures that the preselected pressure side of the hydraulic motor (**A** or **B**) is always connected to the HA control, and thus determines the swivel angle, even if the high-pressure side changes (e. g. -travel drive during a downhill operation). This thereby prevents undesired jerky deceleration and/or braking characteristics.

The travel direction valve (see page 24) is either pressure spring or switched by energizing switching solenoid **a**, depending on the direction of rotation (travel direction).

Electric override

Technical data, solenoid b with DIA45		
	R1	R2
Voltage	12 V (±20 %)	24 V (±20 %)
No override	de-energized	de-energized
Position $V_{g \max}$	energized	energized
Nominal resistance (at 68 °F (20 °C))	4.8 Ω	19.2 Ω
Nominal power	30 W	30 W
Minimum required active current	1.5 A	0.75 A
Duty cycle	100 %	100 %
Type of protection: see connector version on page 62		

Travel direction valve, electric

Technical data, solenoid a with DIA37			
		R1	R2
Voltage		12 V (±20 %)	24 V (±20 %)
Direction of rotation	Operating pressure in		
ccw	B	energized	energized
cw	A	de-energized	de-energized
Nominal resistance (at 68 °F (20 °C))		5.5 Ω	21.7 Ω
Nominal power		26.2 W	26.5 W
Minimum required active current		1.32 A	0.67 A
Duty cycle		100 %	100 %
Type of protection: see connector version on page 62			

▼ **Circuit diagram HA1R1, HA1R2**

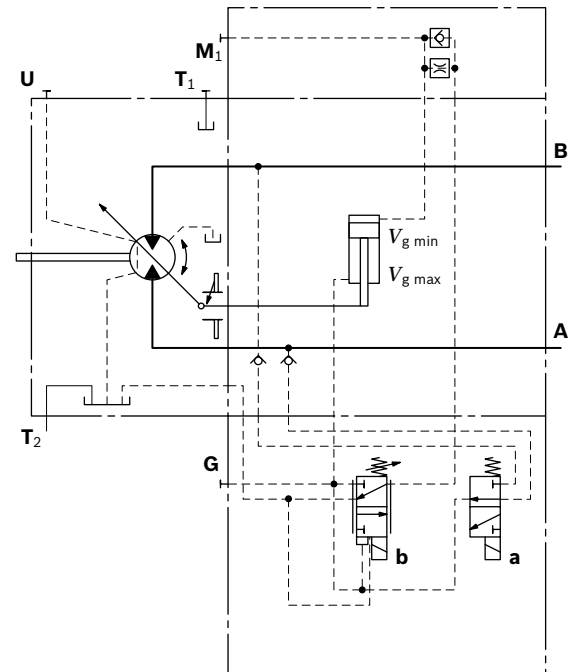

▼ **Circuit diagram HA2R1, HA2R2**

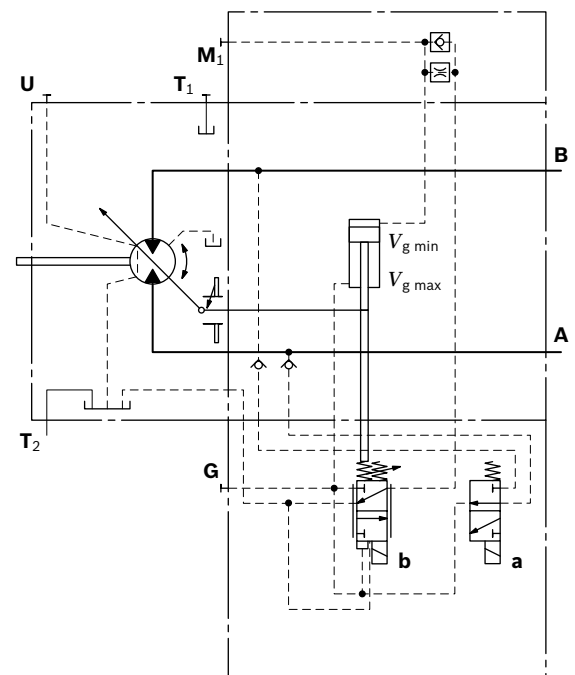

DA – Automatic speed-related control

The variable motor A6VM with automatic speed-related control, type DA, is intended for use in hydrostatic travel drives in combination with the variable pump A4VG with DA control.

A drive-speed-related pilot pressure signal is generated by the A4VG variable pump, and that signal, together with the operating pressure, regulates the swivel angle of the hydraulic motor.

Increasing pump speed, i.e. increasing pilot pressure, causes the motor to swivel to a smaller displacement (lower torque, higher speed), depending on the operating pressure.

If the operating pressure exceeds the pressure setpoint set on the controller, the variable motor swivels to a larger displacement (higher torque, lower speed).

- ▶ Pressure ratio $p_{St}/p_{HD} = 5/100$

DA closed loop control is only suitable for certain types of drive systems and requires review of the engine and vehicle parameters to ensure that the motor is used correctly and that machine operation is safe and efficient. We recommend that all DA applications be reviewed by a Bosch Rexroth application engineer.

Detailed information is available from our sales organization.

Note

The beginning of control and the DA characteristic curve are influenced by case pressure. An increase in case pressure causes a decrease in the beginning of control (see page 6) and thus a parallel shift of the characteristic.

Response time damping

The response time damping is influencing the stroke characteristics of the motor and thus the reaction speed of the machine.

Standard with Size 60 to 215

DA with one sided throttle pin effects the stroking time of the motor from $V_{g\ min}$ to $V_{g\ max}$. (as to table)

▼ Overview Throttle Pins

Size	60	85	115	150	170	215
Groove	[inch] 0.018	0.018	0.022	0.022	0.022	0.022
size	[mm] 0.45	0.45	0.55	0.55	0.55	0.65

DA0 hydraulic travel direction valve, negative control

Depending on the direction of rotation (travel direction), the travel direction valve is switched by using pilot pressures connections X_1 or X_2 .

Direction of rotation	Operating pressure in	Pilot pressure in
cw	A	X_1
ccw	B	X_2

▼ Circuit diagram DA0

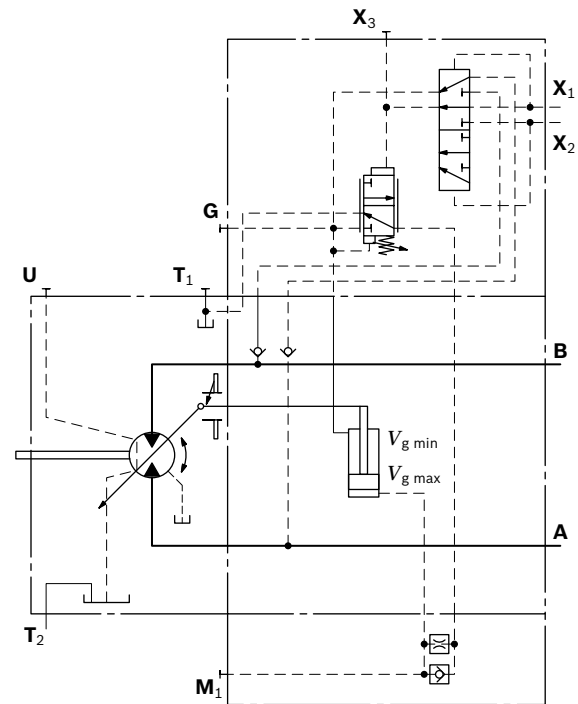

DA1, DA2 electric travel direction valve + electric $V_{g \max}$ circuit, negative control

The travel direction valve is pressure spring offset or switched by energizing switching solenoid **a**, depending on the direction of rotation (travel direction).
 When the switching solenoid **b** is energized, the DA control is overridden and the motor swivels to maximum displacement (high torque, lower speed) (electric $V_{g \max}$ -circuit).

Travel direction valve, electric

Technical data, solenoid a with DIA37		DA1	DA2
Voltage		12 V ($\pm 20\%$)	24 V ($\pm 20\%$)
Direction of rotation	Operating pressure in		
	ccw	B	de-energized
	cw	A	energized
Nominal resistance (at 68 °F (20 °C))		5.5 Ω	21.7 Ω
Nominal power		26.2 W	26.5 W
Minimum required active current		1.32 A	0.67 A
Duty cycle		100 %	100 %
Type of protection: see connector version on page 62			

Electric override

Technical data, solenoid b with DIA37		DA1	DA2
Voltage		12 V ($\pm 20\%$)	24 V ($\pm 20\%$)
No override		de-energized	de-energized
Position $V_{g \max}$		energized	energized
Nominal resistance (at 68 °F (20 °C))		5.5 Ω	21.7 Ω
Nominal power		26.2 W	26.5 W
Minimum required active current		1.32 A	0.67 A
Duty cycle		100 %	100 %
Type of protection: see connector version on page 62			

▼ **Circuit diagram DA1, DA2**

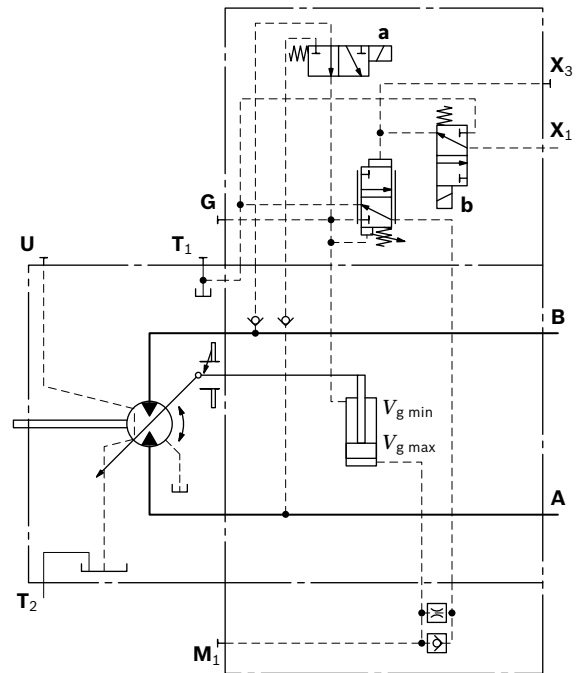

Electric travel direction valve (for DA, HA.R)

Application in travel drives in closed circuits. The travel direction valve of the motor is actuated by an electric signal that also switches the swivel direction of the travel drive pump (e. g. A4VG with DA control valve).

If the pump in the closed circuit is switched to the neutral position or into reverse, the vehicle may experience jerky deceleration or braking, depending on the vehicle's mass and current travel speed.

When the travel direction valve of the pump (e. g. 4/3-directional valve of the DA-control) is switched to

- ▶ the neutral position, the electric circuitry causes the previous signal on the travel direction valve on the motor to be retained.
- ▶ Reversing, the travel direction valve causes the travel direction valve of the motor to switch to the other travel direction following a time delay (approx. 0.8 s) with respect to the pump.

As a result, jerky deceleration or braking is prevented in both cases.

▼ Circuit diagram - electric travel direction valve

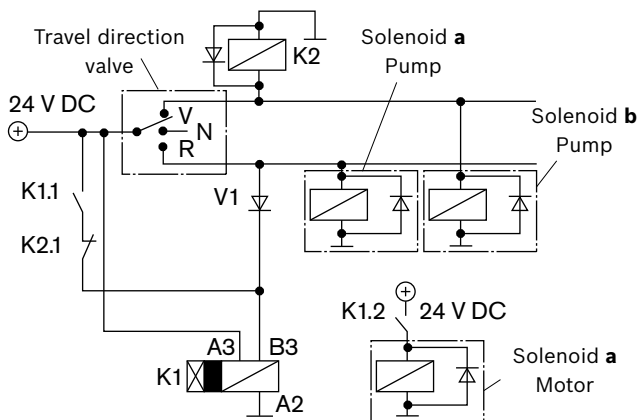

The diodes and relays shown are not included in the scope of delivery of the motor.

▼ Control DA1, DA

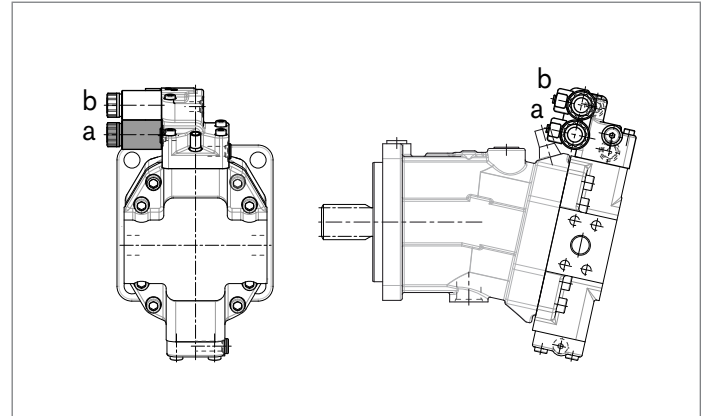

▼ HA1R., HA2R. control

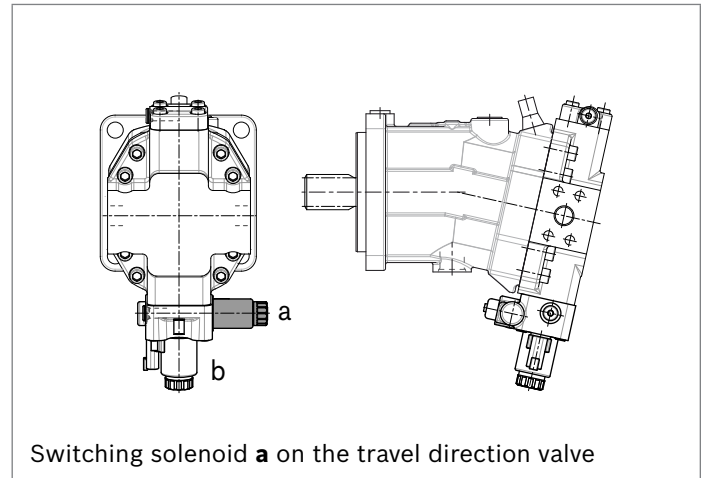

Dimensions size 60

EP5, EP6 – Proportional electric control, negative control

Port plate 2 – SAE working ports **A** and **B** at side, opposite

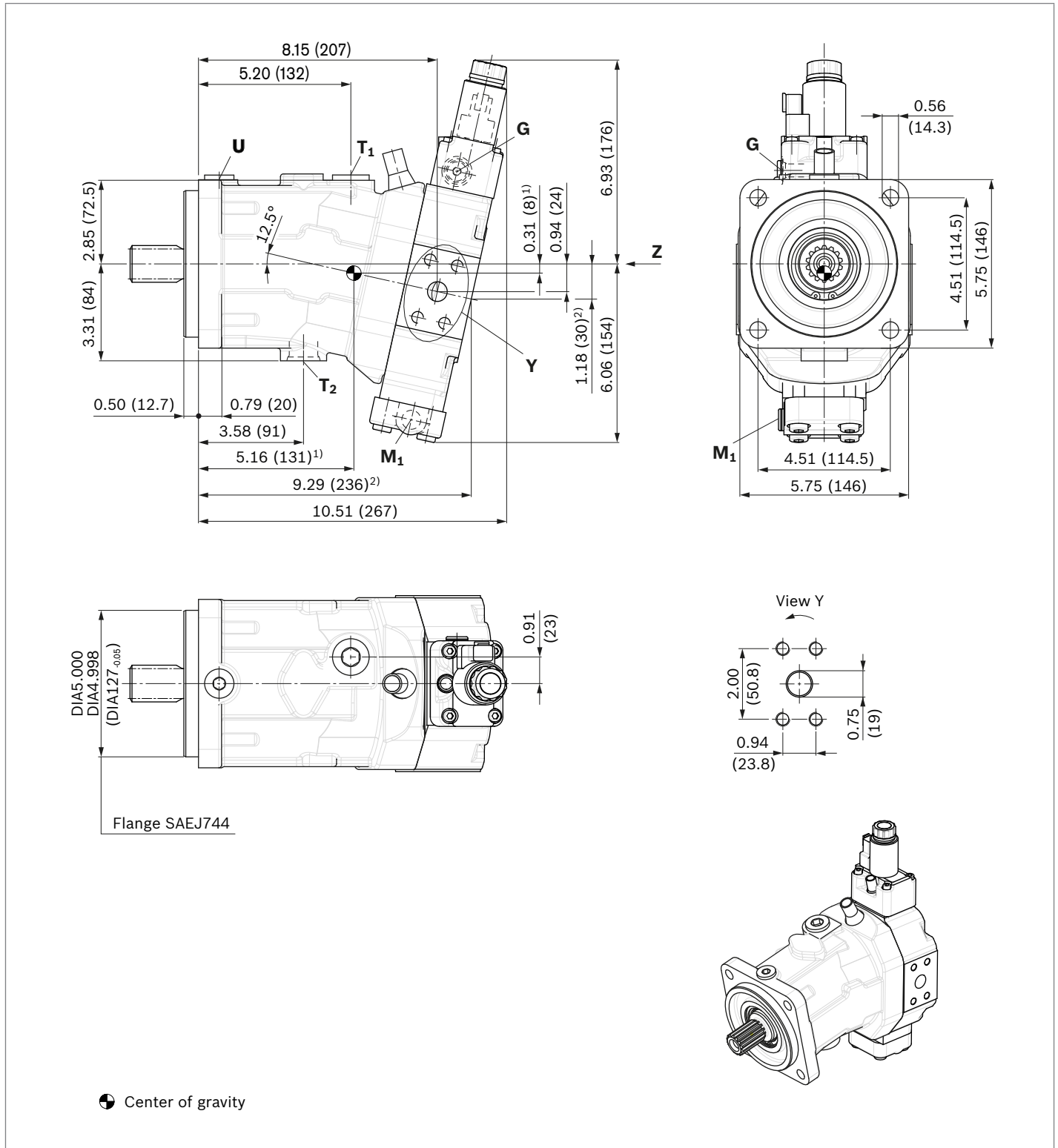

1) Port plate 1 – SAE working ports **A** and **B** at rear

▼ **Location of working ports on port plates (view Z)**

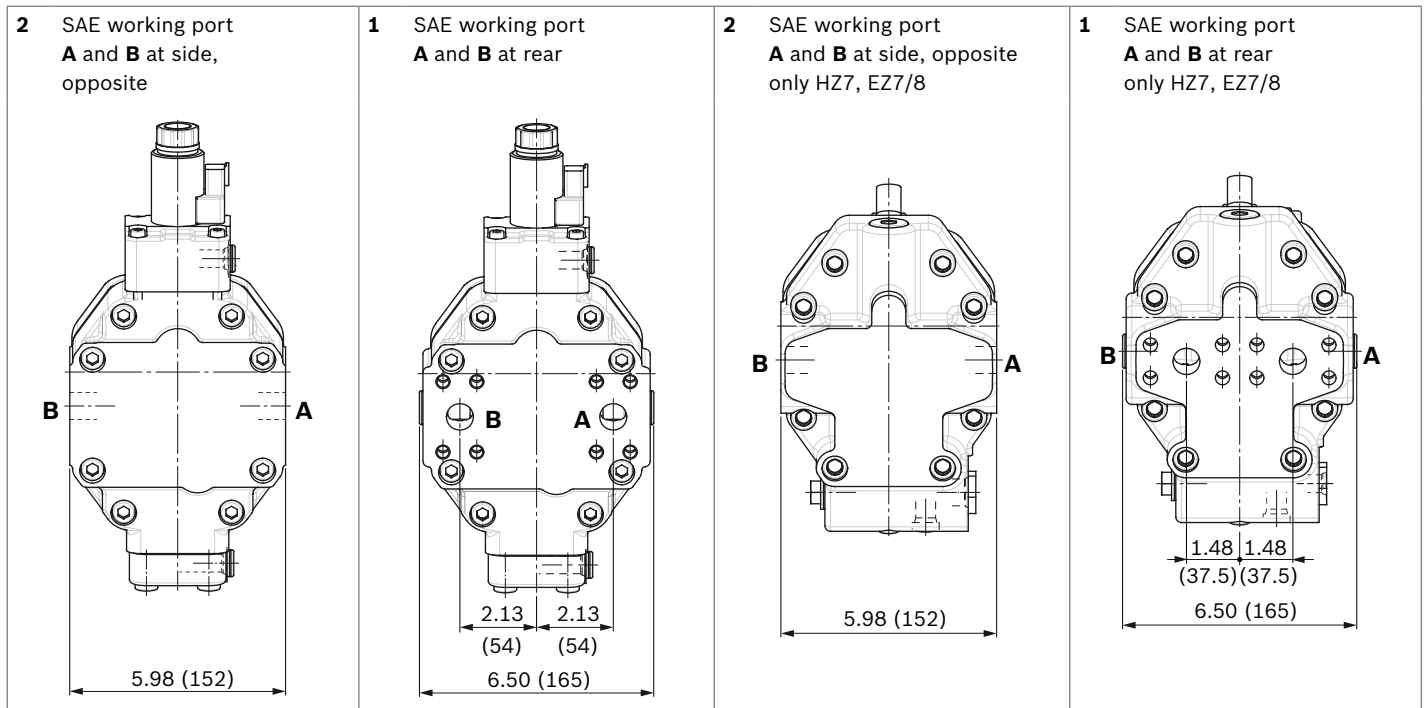

▼ **Splined shaft SAE J744**

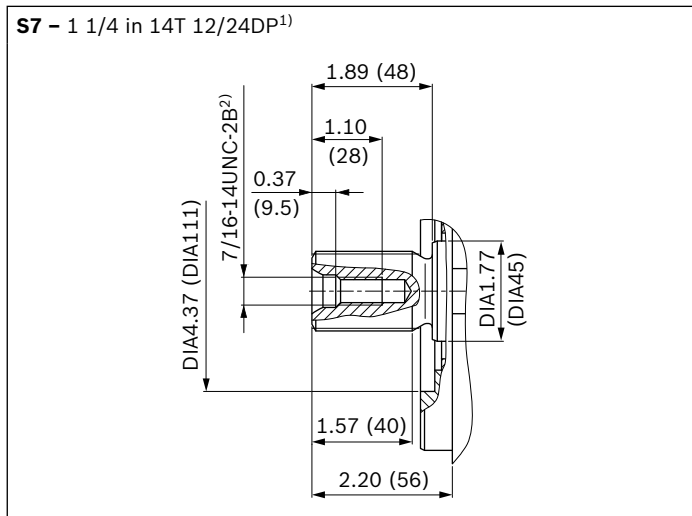

1) Involute toothing acc. to ANSI B92.1a, 30° pressure angle, flat root, side fit, tolerance class 5

2) Thread according to ASME B1.1

Ports	Standard	Size	p_{\max} [psi (bar)] ¹⁾	Status ⁶⁾
A, B ⁴⁾ Working port Mounting bolt A/B, screw grade 8 with hardened washer	SAE J518 ²⁾ ASME B1.1	3/4 in 3/8 in - 16 UNC-2B; 0.83 (21) deep	7250 psi (500 bar)	O
T ₁ Drain port	ISO 11926 ⁵⁾	1 1/16 in -12 UN-2B; 0.79 (20) deep	45 (3)	X ³⁾
T ₂ Drain port	ISO 11926 ⁵⁾	1 1/16 in -12 UN-2B; 0.79 (20) deep	45 (3)	O ³⁾
G Synchronous control	ISO 11926 ⁵⁾	9/16 in -18 UNF-2B; 0.51 (13) deep	7250 psi (500 bar)	X
U Bearing flushing	ISO 11926 ⁵⁾	7/8 in -14 UNF-2B; 0.67 (17) deep	45 (3)	X
X Pilot signal (HP, HZ, HA1T/HA2T)	ISO 11926 ⁵⁾	9/16 in -18 UNF-2B; 0.51 (13) deep	1450 (100)	O
X Pilot signal (HA1, HA2)	ISO 11926 ⁵⁾	9/16 in -18 UNF-2B; 0.51 (13) deep	45 (3)	X
X ₁ , X ₂ Pilot signal (DA0)	ISO 8434-1	SDSC-L8×M12-F	580 (40)	O
X ₁ Pilot signal (DA1, DA2)	ISO 11926 ⁵⁾	9/16 in -18 UNF-2B; 0.51 (13) deep	580 (40)	O
X ₃ Pilot signal (DA1, DA2)	ISO 11926 ⁵⁾	9/16 in -18 UNF-2B; 0.51 (13) deep	580 (40)	X
M ₁ Measuring stroking chamber	ISO 11926 ⁵⁾	9/16 in -18 UNF-2B; 0.51 (13) deep	7250 psi (500 bar)	X

- 1) Momentary pressure spikes may occur depending on the application. Keep this in mind when selecting measuring devices and fittings.
- 2) Only dimensions according to SAE J518.
- 3) Depending on installation position, T₁ or T₂ must be connected (see also installation instructions on page 72).

- 4) For the maximum utilization of pressure, only grade 8 screws and hardened washers are to be used to tighten the SAE flange shells.
- 5) The spot face can be deeper than as specified in the standard.
- 6) O = Must be connected (plugged on delivery)
X = Plugged (in normal operation)

▼ **EP1, EP2** – Electric proportional control,
 positive control

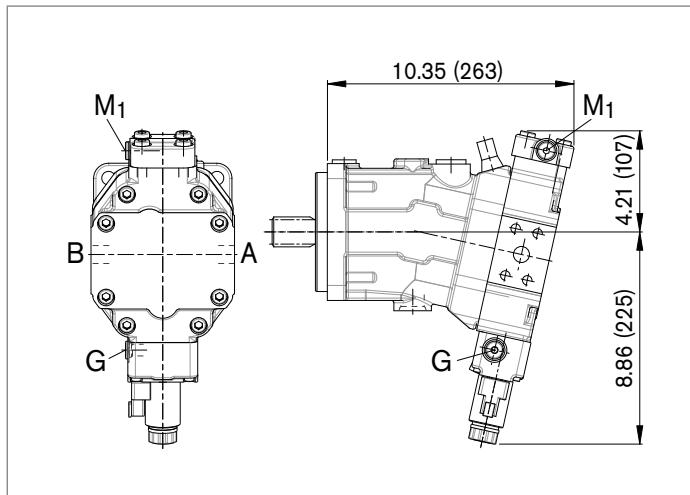

▼ **EP5D1, EP6D1** – Electric proportional control,
 negative control, with pressure control, fixed setting

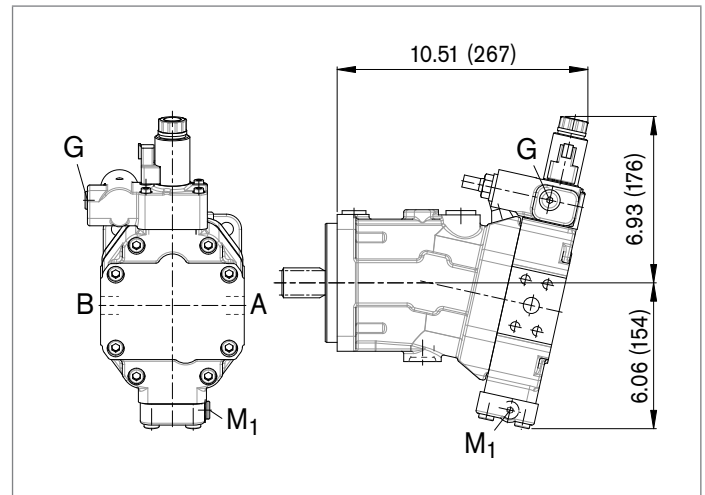

▼ **HP1, HP2** – Hydraulic proportional control,
 positive control

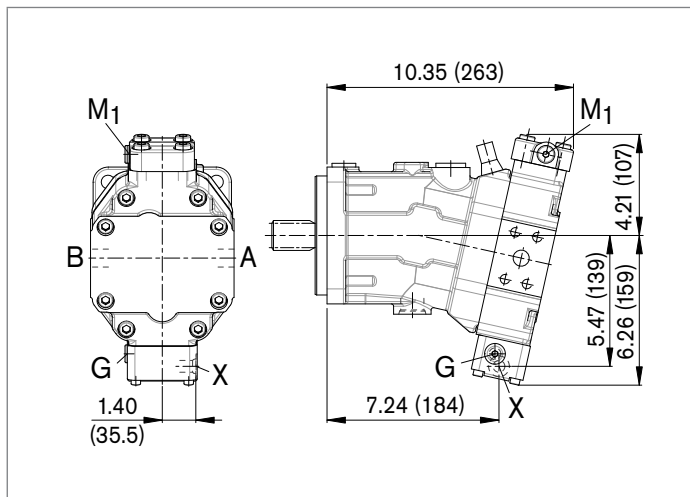

▼ **HP5, HP6** – Hydraulic proportional control,
 negative control

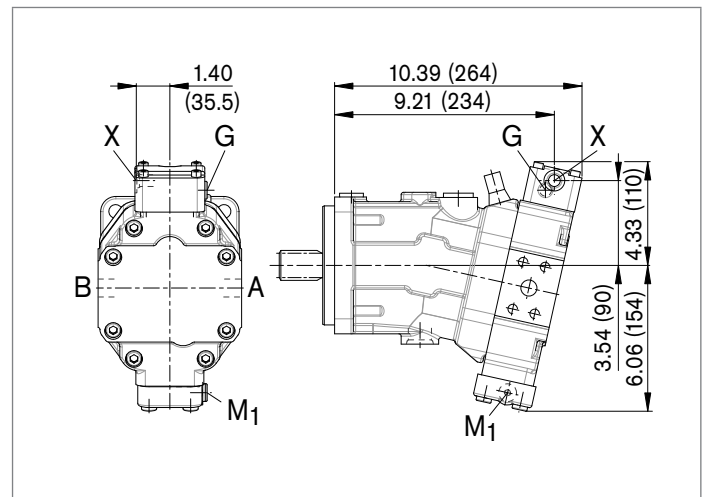

▼ **HP5D1, HP6D1** – Hydraulic proportional control,
 negative control, with pressure control, fixed setting

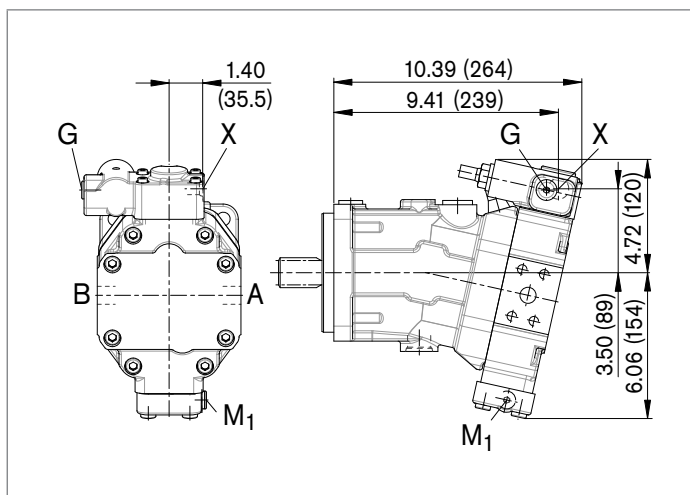

▼ **HZ7** – Hydraulic two-point control, negative control

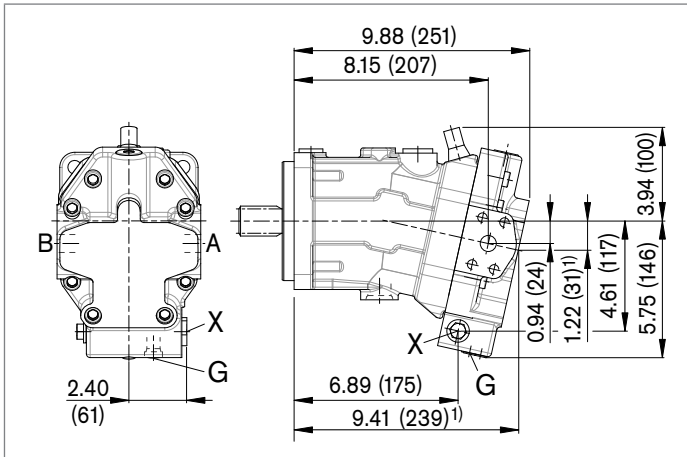

▼ **EZ7, EZ8** – Electric two-point control, negative control

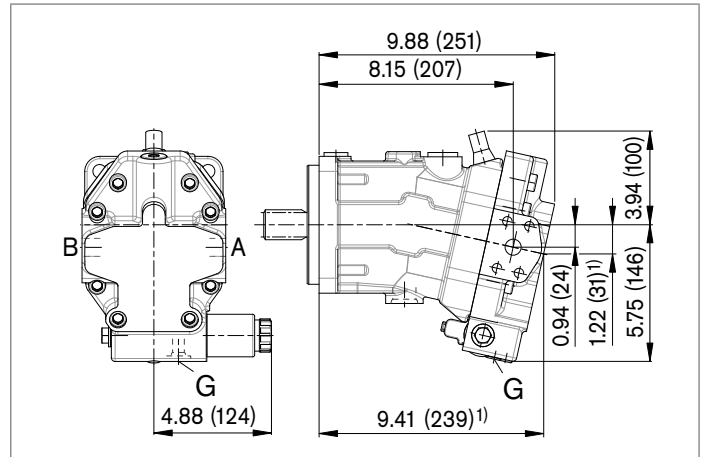

▼ **HA1, HA2 / HA1T3, HA2T3** – Automatic high-pressure-related control, positive control, with override hydraulic remote controlled, proportional

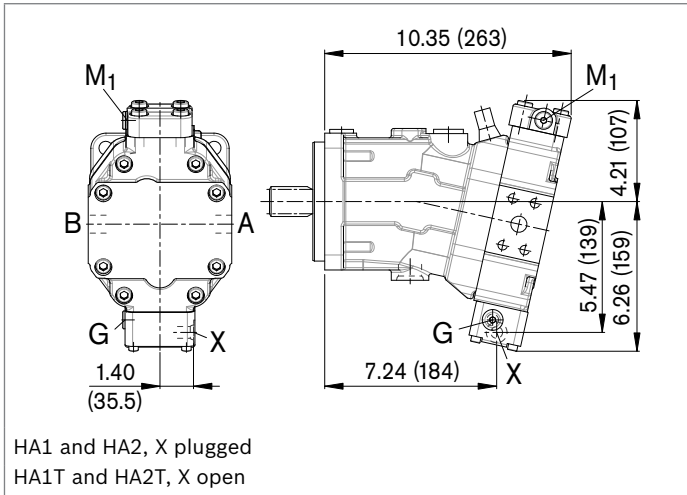

▼ **HA1U1, HA2U2** – Automatic high-pressure-related control, positive control, with override, electric, two-point

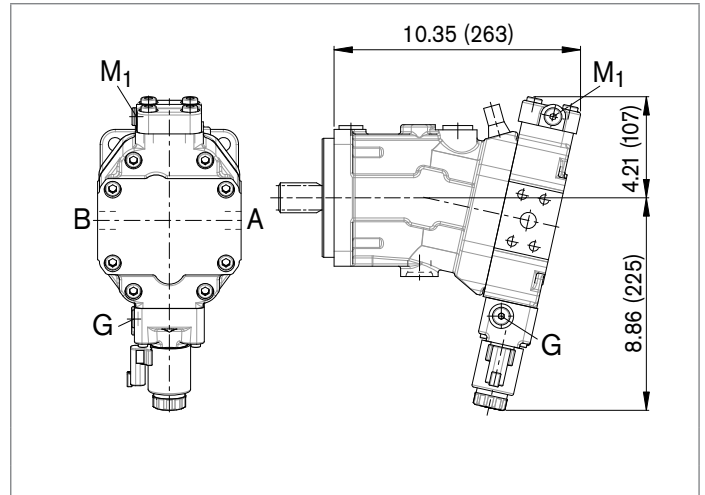

▼ **HA1R1, HA2R2** – Automatic high-pressure-related control, positive control, with override, electric and travel direction valve, electric

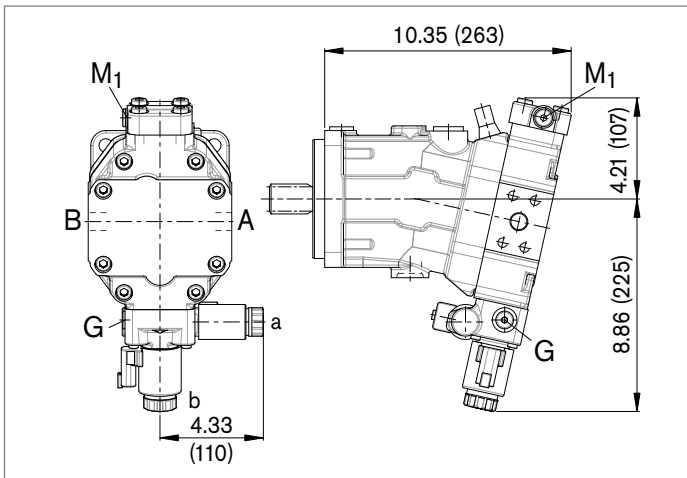

1) Port plate 1 – SAE working ports **A** and **B** at rear

- ▼ **DA0** – Automatic speed-related control, negative control, with hydraulic travel direction valve

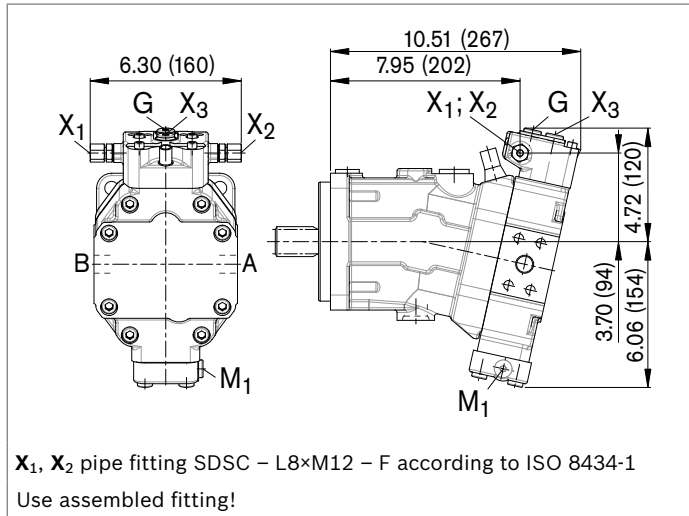

- ▼ **DA1, DA2** – Automatic speed-related control, negative control, with electric travel direction valve and electric $V_{g \max}$ switch

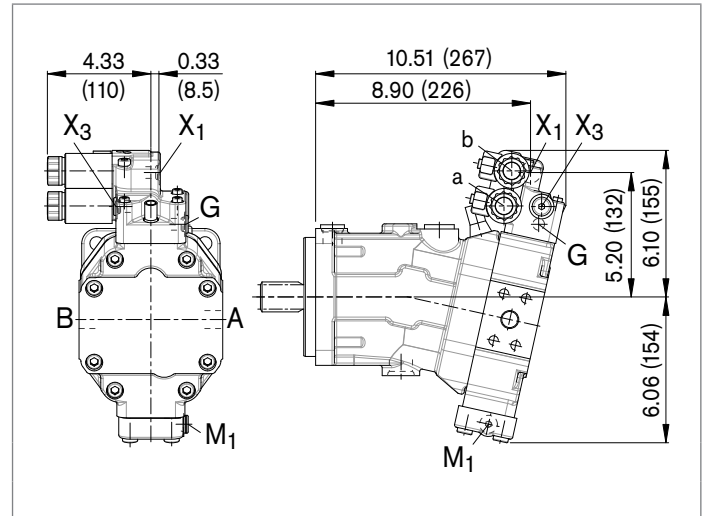

Dimensions size 85

EP5, EP6 – Proportional electric control, negative control, with Mounting flange C2

Port plate 2 – SAE working ports **A** and **B** at side, opposite

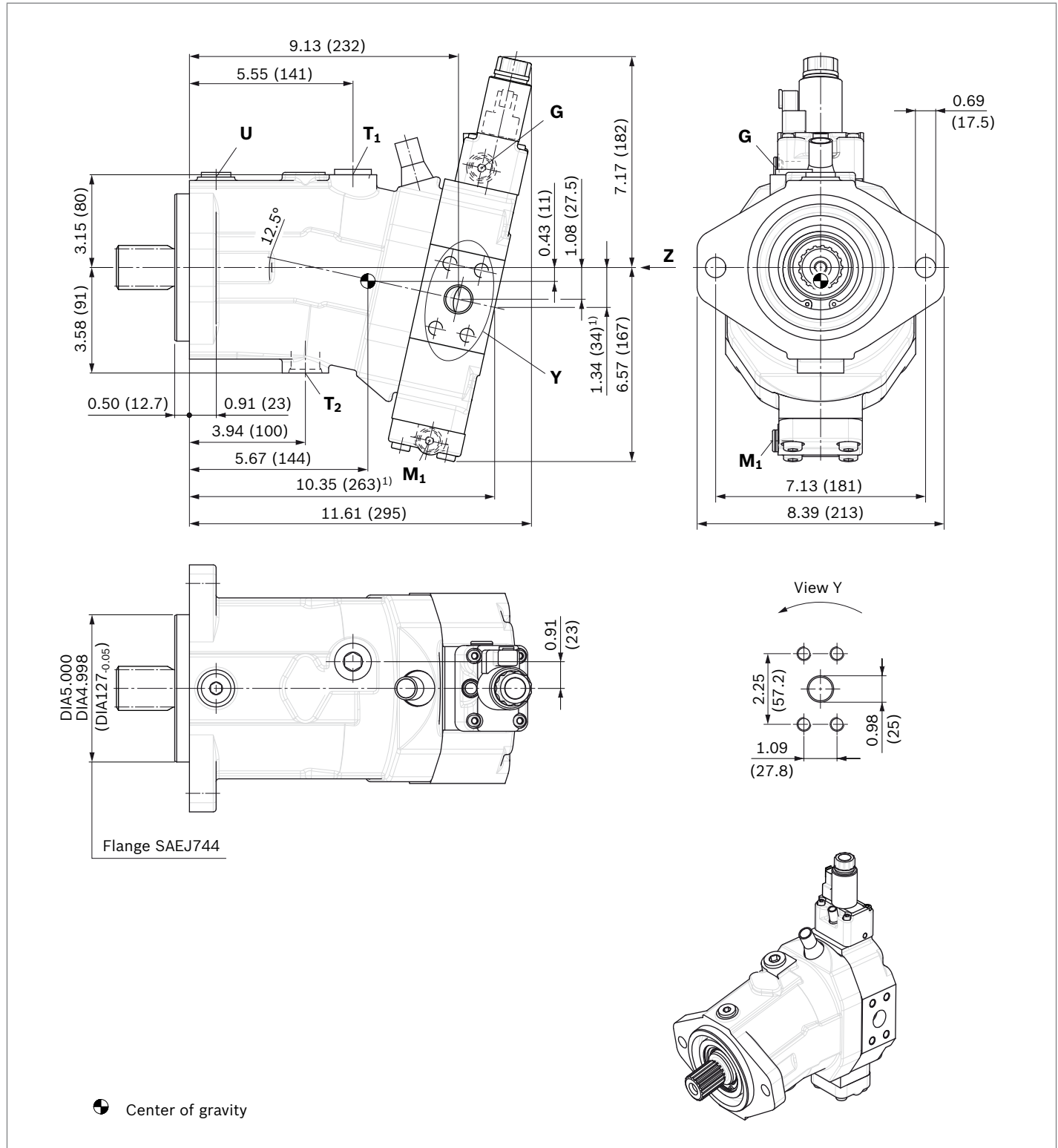

1) Port plate 1 – SAE working ports **A** and **B** at rear

Dimensions size 85

EP5, EP6 – Proportional electric control, negative control, with Mounting flange C4

Port plate 2 – SAE working ports **A** and **B** at side, opposite

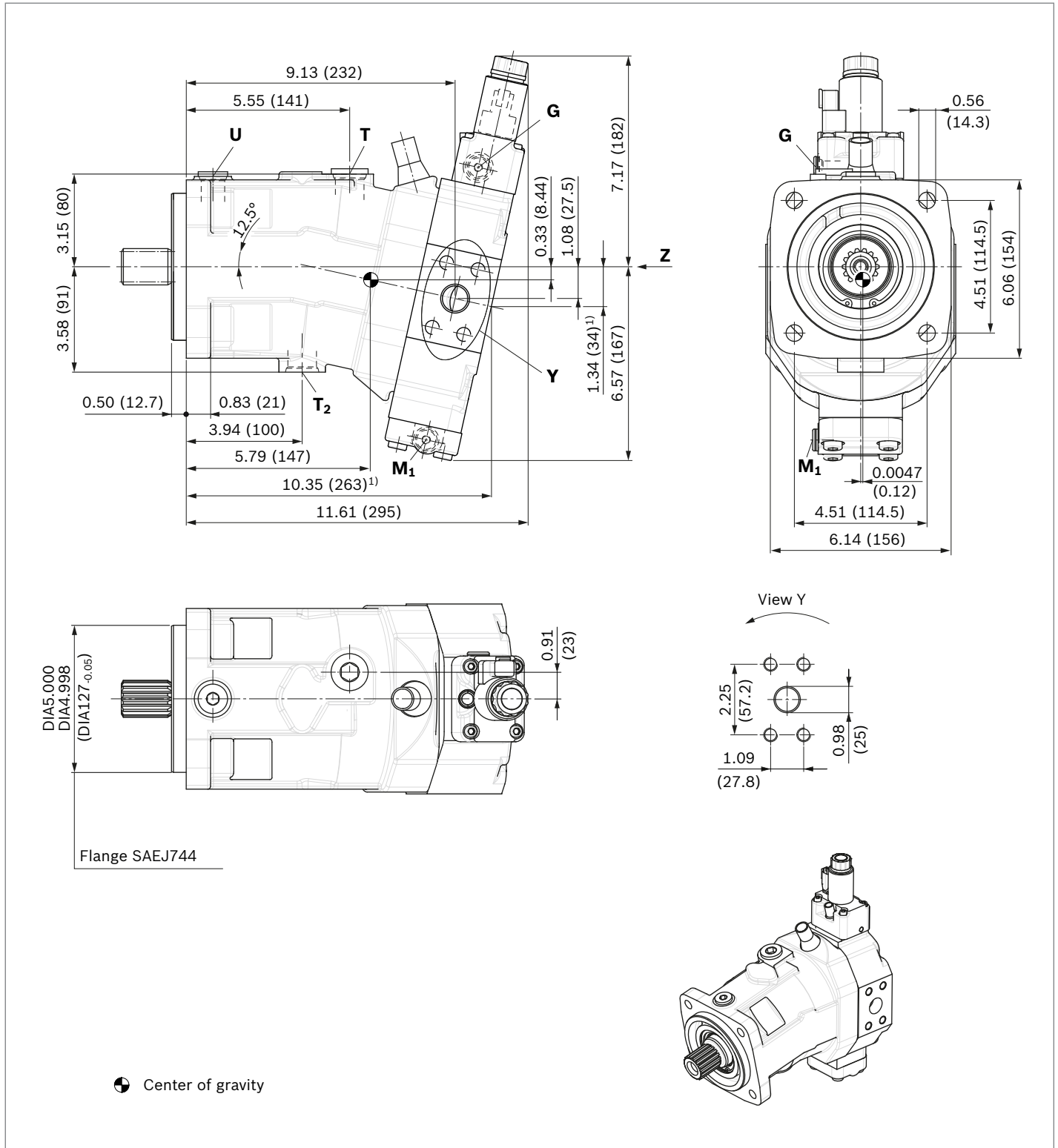

▼ **Location of working ports on port plates (view Z)**

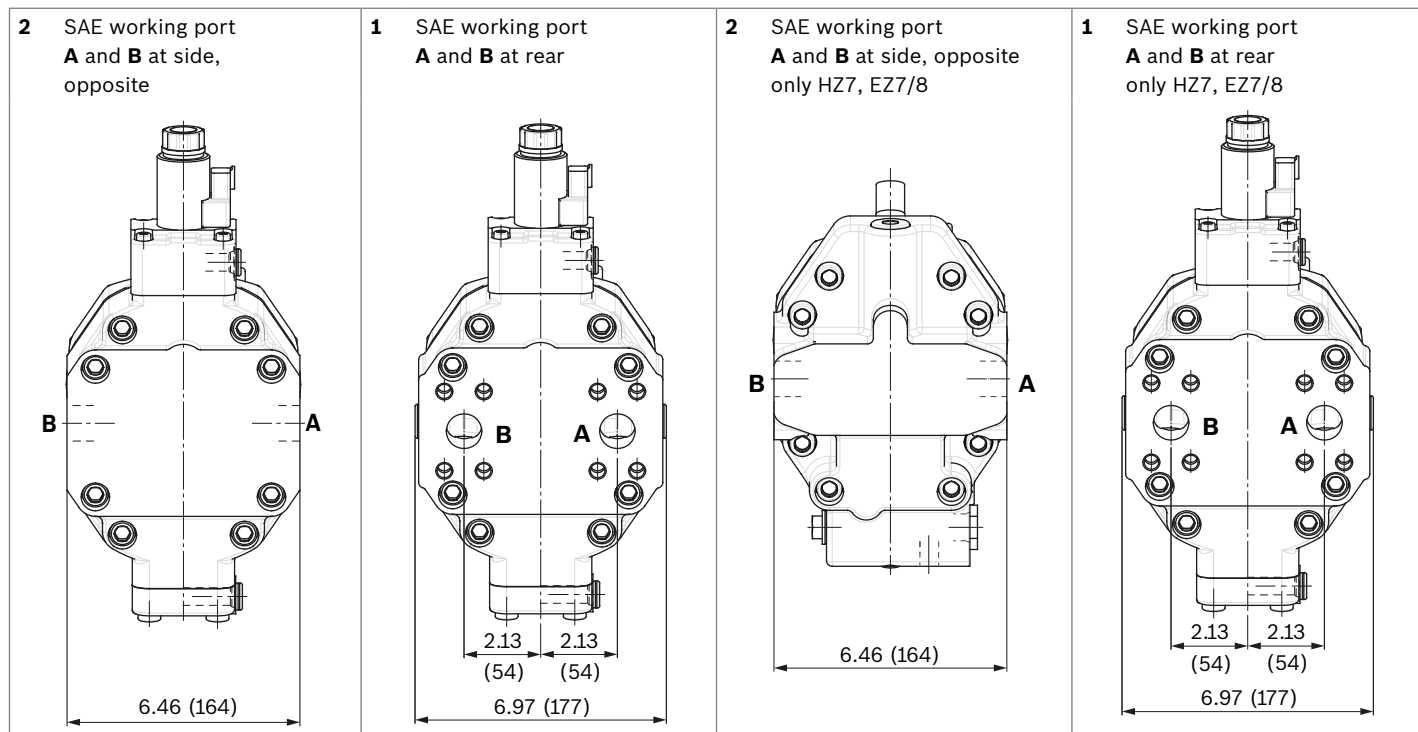

▼ **Splined shaft SAE J744**

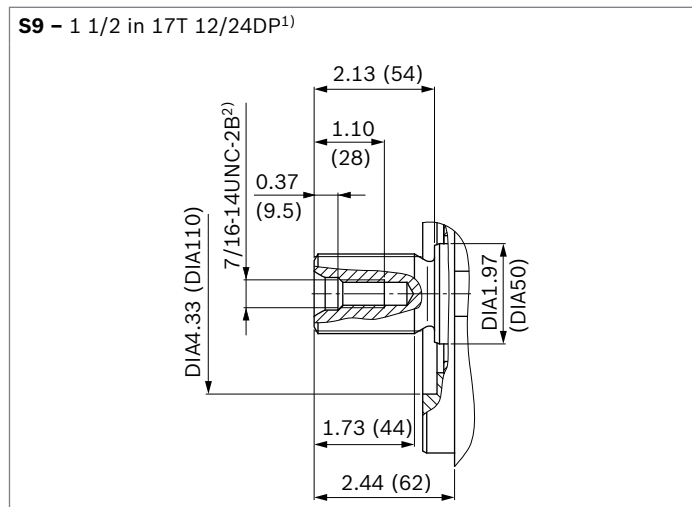

1) Involute toothing acc. to ANSI B92.1a, 30° pressure angle, flat root, side fit, tolerance class 5

2) Thread according to ASME B1.1

Ports		Standard	Size	p_{max} [psi (bar)] ¹⁾	Status ⁶⁾
A, B ⁴⁾	Working port	SAE J518 ²⁾	1 in	7250 psi (500 bar)	O
	Mounting bolt A/B, screw grade 8 with hardened washer	ASME B1.1	7/16 in -14 UNC-2B; 0.87 (22) deep		
T ₁	Drain port	ISO 11926 ⁵⁾	1 1/16 in -12 UN-2B; 0.79 (20) deep	45 (3)	X ³⁾
T ₂	Drain port	ISO 11926 ⁵⁾	1 1/16 in -12 UN-2B; 0.79 (20) deep	45 (3)	O ³⁾
G	Synchronous control	ISO 11926 ⁵⁾	9/16 in -18 UNF-2B; 0.51 (13) deep	7250 psi (500 bar)	X
U	Bearing flushing	ISO11926 ⁵⁾	7/8 in -14 UNF-2B; 0.67 (17) deep	45 (3)	X
X	Pilot signal (HP, HZ, HA1T/HA2T)	ISO 11926 ⁵⁾	9/16 in -18 UNF-2B; 0.51 (13) deep	1450 (100)	O
X	Pilot signal (HA1, HA2)	ISO 11926 ⁵⁾	9/16 in -18 UNF-2B; 0.51 (13) deep	45 (3)	X
X ₁ , X ₂	Pilot signal (DA0)	ISO 8434-1	SDSC-L8×M12-F	580 (40)	O
X ₁	Pilot signal (DA1, DA2)	ISO 11926 ⁵⁾	9/16 in -18 UNF-2B; 0.51 (13) deep	580 (40)	O
X ₃	Pilot signal (DA1, DA2)	ISO 11926 ⁵⁾	9/16 in -18 UNF-2B; 0.51 (13) deep	580 (40)	X
M ₁	Measuring stroking chamber	ISO 11926 ⁵⁾	9/16 in -18 UNF-2B; 0.51 (13) deep	7250 psi (500 bar)	X

1) Momentary pressure spikes may occur depending on the application. Keep this in mind when selecting measuring devices and fittings.

2) Only dimensions according to SAE J518.

3) Depending on installation position, T₁ or T₂ must be connected (see also installation instructions on page 72).

4) For the maximum utilization of pressure, only grade 8 screws and hardened washers are to be used to tighten the SAE flange shells.

5) The spot face can be deeper than as specified in the standard.

6) O = Must be connected (plugged on delivery)

X = Plugged (in normal operation)

▼ **EP1, EP2** – Electric proportional control, positive control

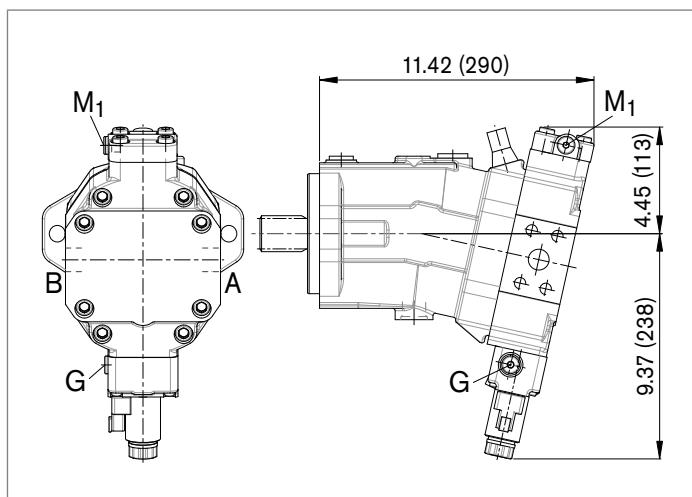

▼ **EP5D1, EP6D1** – Electric proportional control, negative control, with pressure control, fixed setting

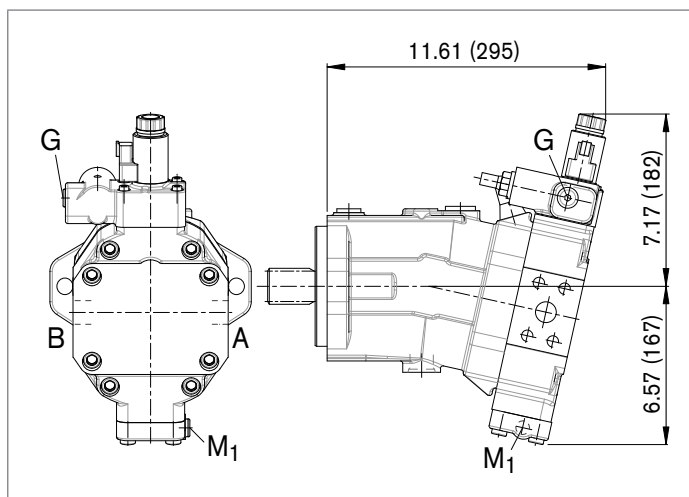

▼ **HP1, HP2** – Hydraulic proportional control, positive control

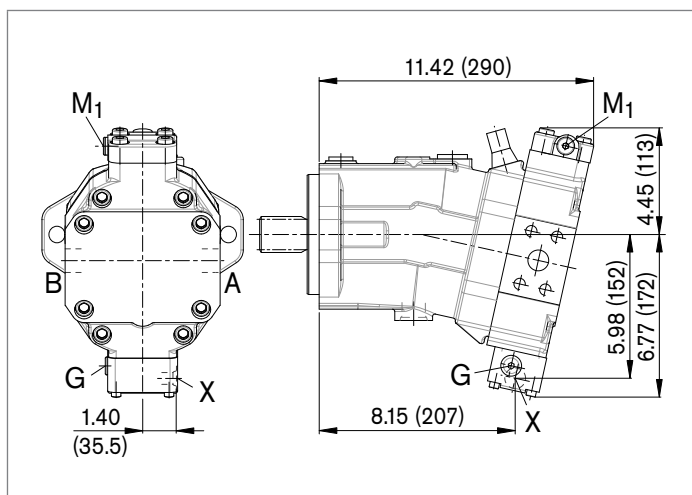

▼ **HP5, HP6** – Hydraulic proportional control, negative control

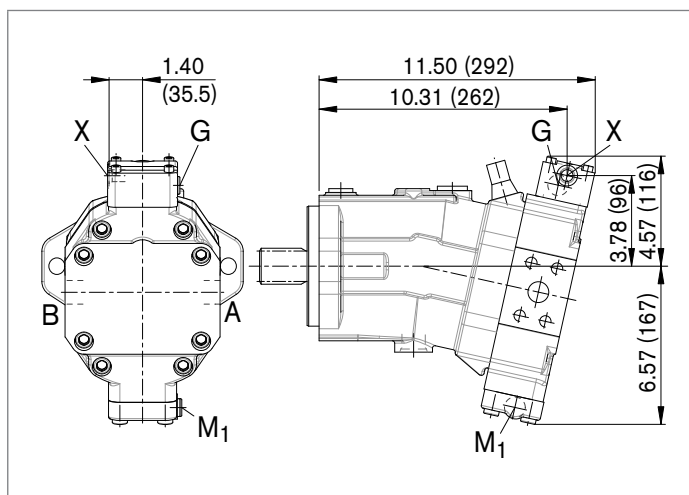

▼ **HP5D1, HP6D1** – Hydraulic proportional control, negative control, with pressure control, fixed setting

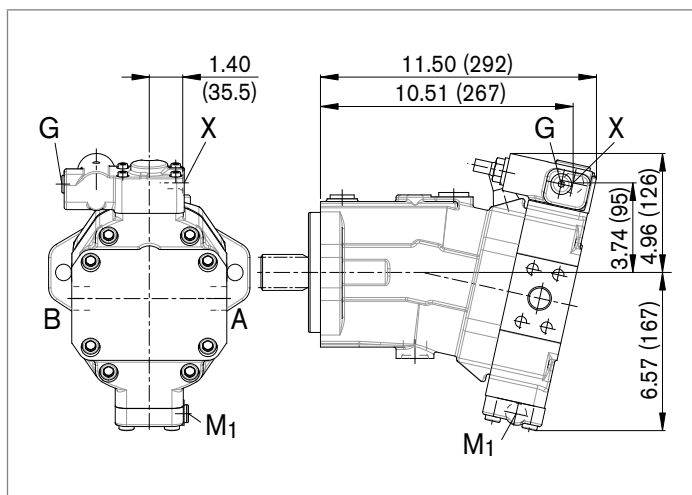

▼ **HZ7** – Hydraulic two-point control,
 negative control

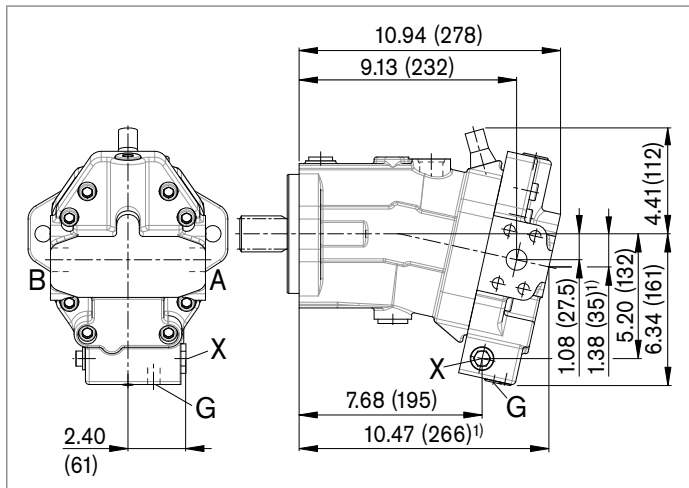

▼ **EZ7, EZ8** – Electric two-point control,
 negative control

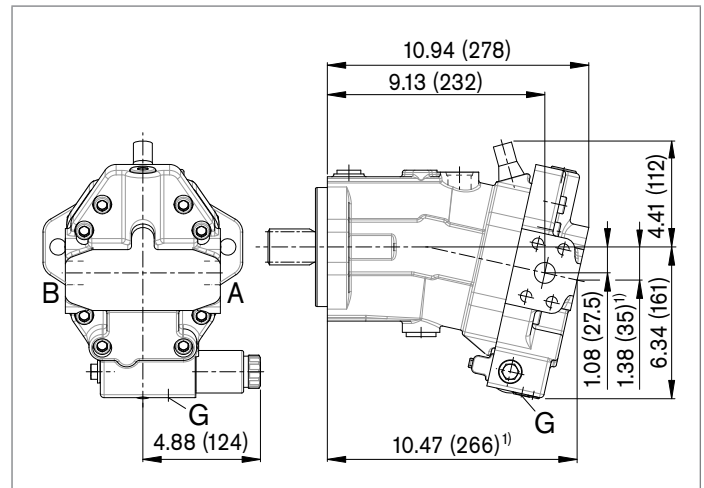

▼ **HA1, HA2 / HA1T3, HA2T3** – Automatic high-pressure-related
 control, positive control, with override hydraulic remote controlled,
 proportional

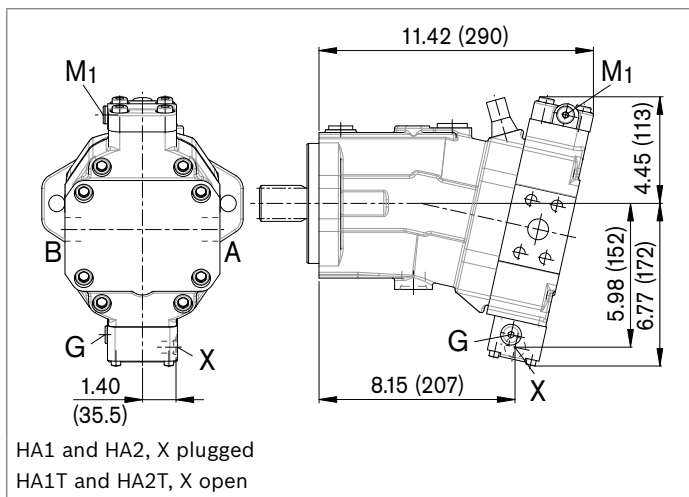

▼ **HA1U1, HA2U2** – Automatic high-pressure-related control,
 positive control, with override, electric, two-point

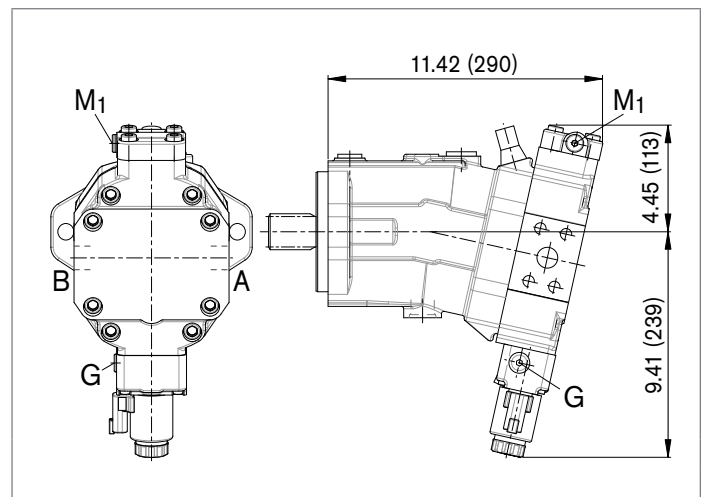

▼ **HA1R1, HA2R2** – Automatic high-pressure-related control,
 positive control, with override, electric and travel direction
 valve, electric

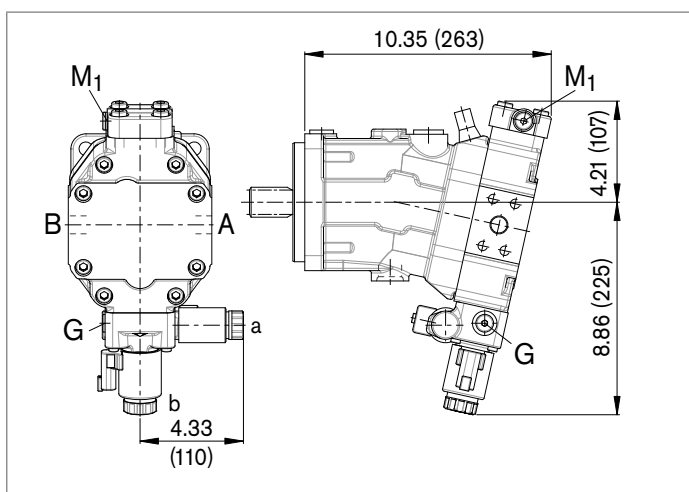

1) Port plate 1 – SAE working ports **A** and **B** at rear

▼ **DA0** – Automatic speed-related control, negative control, with hydraulic travel direction valve

▼ **DA1, DA2** – Automatic speed-related control, negative control, with electric travel direction valve and electric $V_{g\max}$ switch

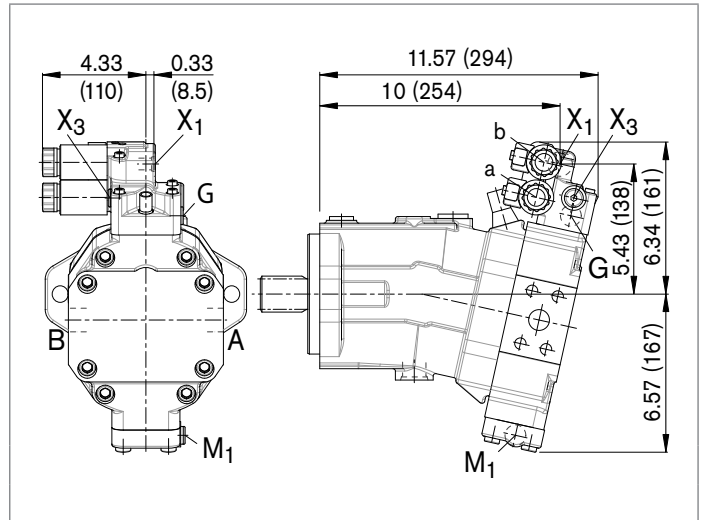
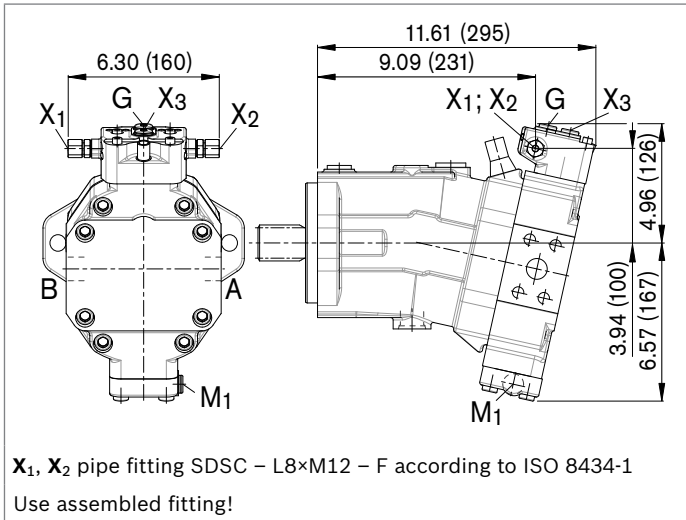

Dimensions size 115

EP5, EP6 – Proportional electric control, negative control

Port plate 2 – SAE working ports **A** and **B** at side, opposite

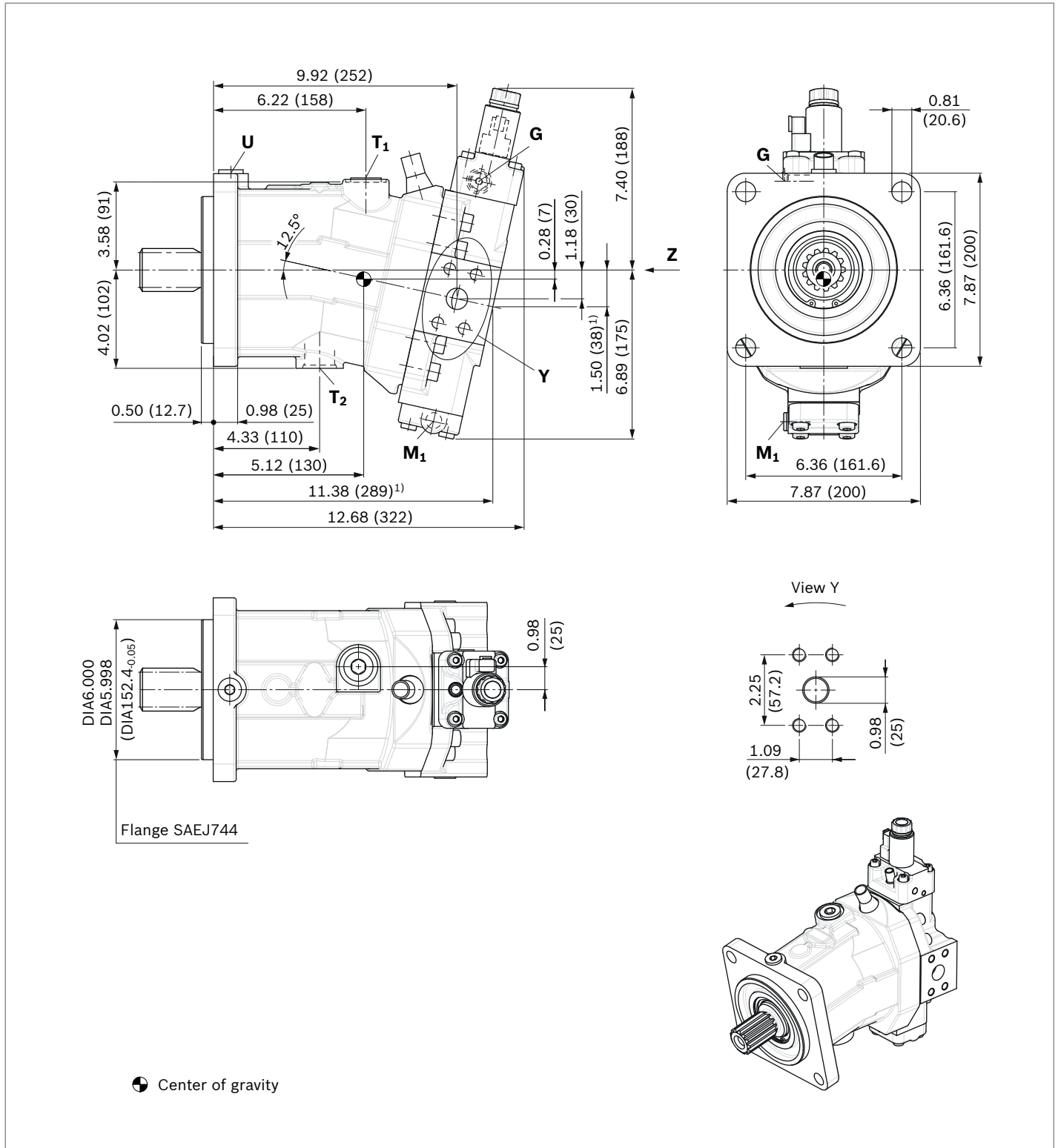

▼ **Location of working ports on port plates (view Z)**

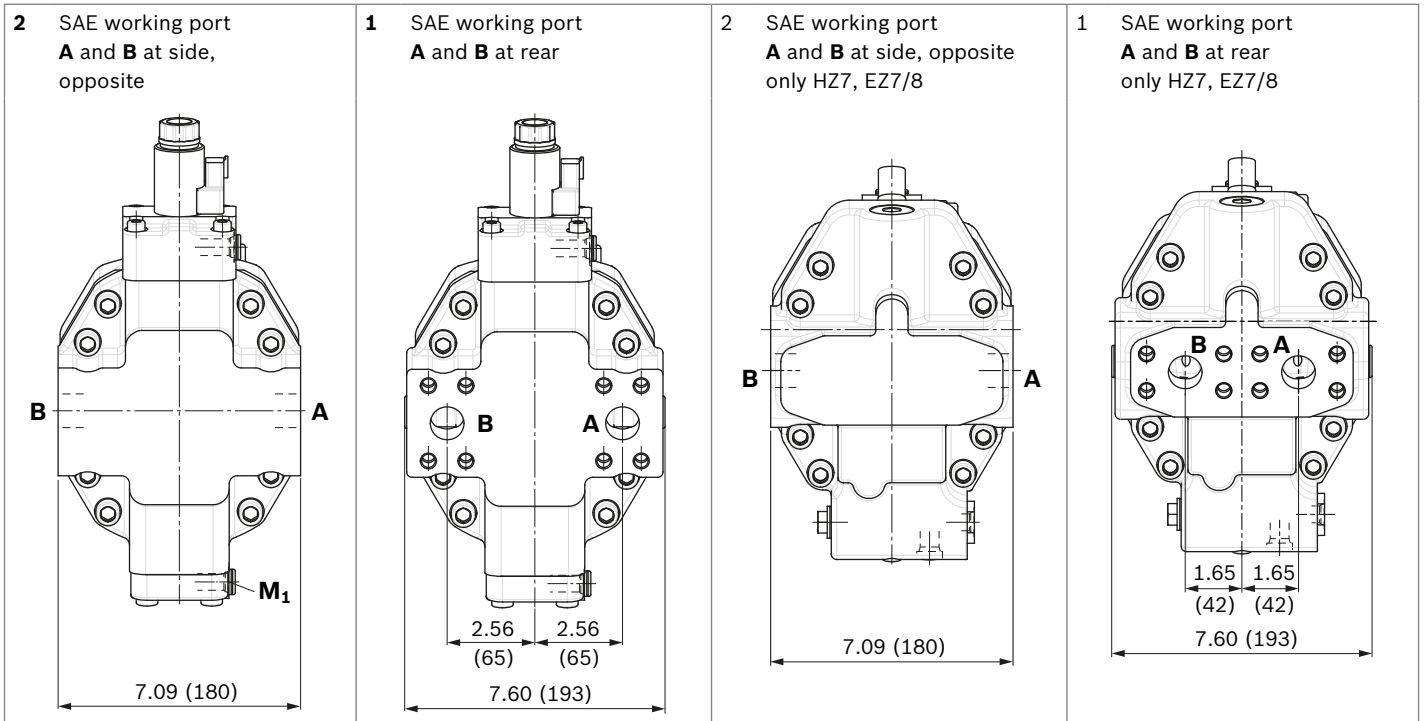

▼ **Splined shaft SAE J744**

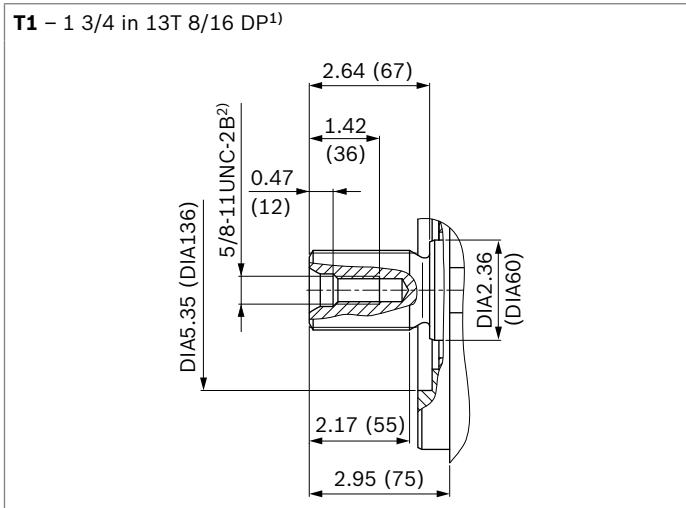

1) Involute toothing acc. to ANSI B92.1a, 30° pressure angle, flat root, side fit, tolerance class 5
 2) Thread according to ASME B1.1

Ports		Standard	Size	p_{max} [psi (bar)] ¹⁾	Status ⁶⁾
A, B ⁴⁾	Working port	SAE J518 ²⁾	1 in	7250 psi (500 bar)	O
	Mounting bolt A/B, screw grade 8 with hardened washer	ASME B1.1	7/16 in -14 UNC-2B; 0.87 (22) deep		
T ₁	Drain port	ISO 11926 ⁵⁾	1 1/16 in -12 UN-2B; 0.79 (20) deep	45 (3)	X ³⁾
T ₂	Drain port	ISO 11926 ⁵⁾	1 5/16 in -12 UN-2B; 0.79 (20) deep	45 (3)	O ³⁾
G	Synchronous control	ISO 11926 ⁵⁾	9/16 in -18 UNF-2B; 0.51 (13) deep	7250 psi (500 bar)	X
U	Bearing flushing	ISO11926 ⁵⁾	7/8 in -14 UNF-2B; 0.67 (17) deep	45 (3)	X
X	Pilot signal (HP, HZ, HA1T/HA2T)	ISO 11926 ⁵⁾	9/16 in -18 UNF-2B; 0.51 (13) deep	1450 (100)	O
X	Pilot signal (HA1, HA2)	ISO 11926 ⁵⁾	9/16 in -18 UNF-2B; 0.51 (13) deep	45 (3)	X
X ₁ , X ₂	Pilot signal (DA0)	ISO 8434-1	SDSC-L8×M12-F	580 (40)	O
X ₁	Pilot signal (DA1, DA2)	ISO 11926 ⁵⁾	9/16 in -18 UNF-2B; 0.51 (13) deep	580 (40)	O
X ₃	Pilot signal (DA1, DA2)	ISO 11926 ⁵⁾	9/16 in -18 UNF-2B; 0.51 (13) deep	580 (40)	X
M ₁	Measuring stroking chamber	ISO 11926 ⁵⁾	9/16 in -18 UNF-2B; 0.51 (13) deep	7250 psi (500 bar)	X

1) Momentary pressure spikes may occur depending on the application. Keep this in mind when selecting measuring devices and fittings.

2) Only dimensions according to SAE J518.

3) Depending on installation position, T₁ or T₂ must be connected (see also installation instructions on page 72).

4) For the maximum utilization of pressure, only grade 8 screws and hardened washers are to be used to tighten the SAE flange shells.

5) The spot face can be deeper than as specified in the standard.

6) O = Must be connected (plugged on delivery)

X = Plugged (in normal operation)

▼ **EP1, EP2** – Electric proportional control, positive control

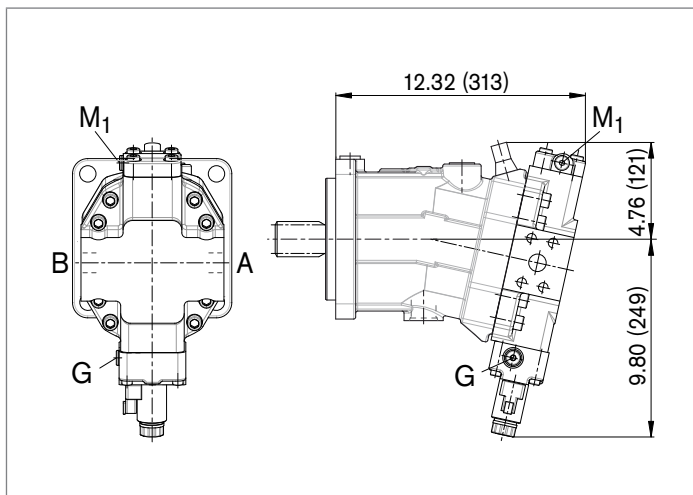

▼ **EP5D1, EP6D1** – Electric proportional control, negative control, with pressure control, fixed setting

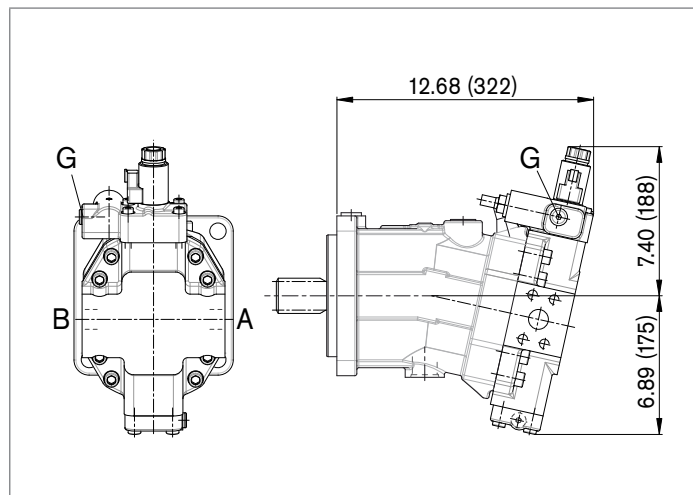

▼ **HP1, HP2** – Hydraulic proportional control, positive control

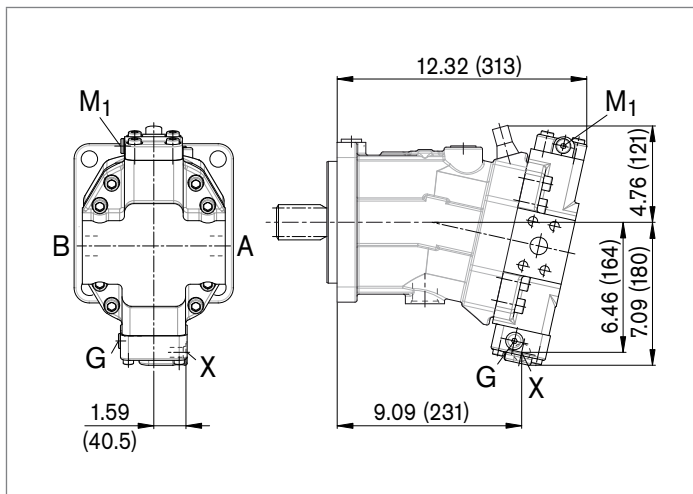

▼ **HP5, HP6** – Hydraulic proportional control, negative control

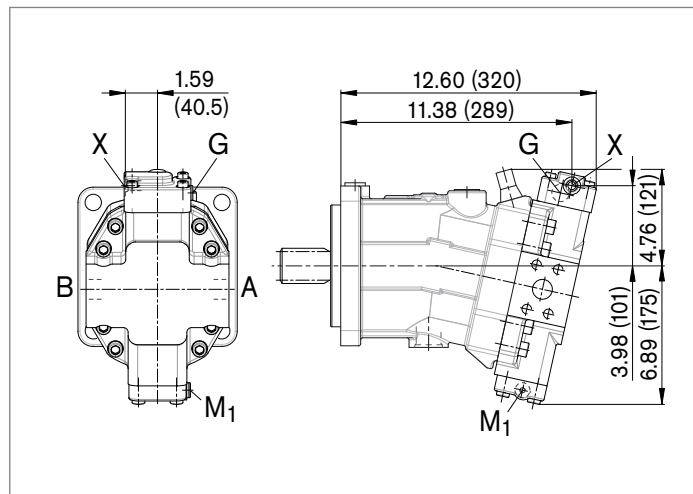

▼ **HP5D1, HP6D1** – Hydraulic proportional control, negative control, with pressure control, fixed setting

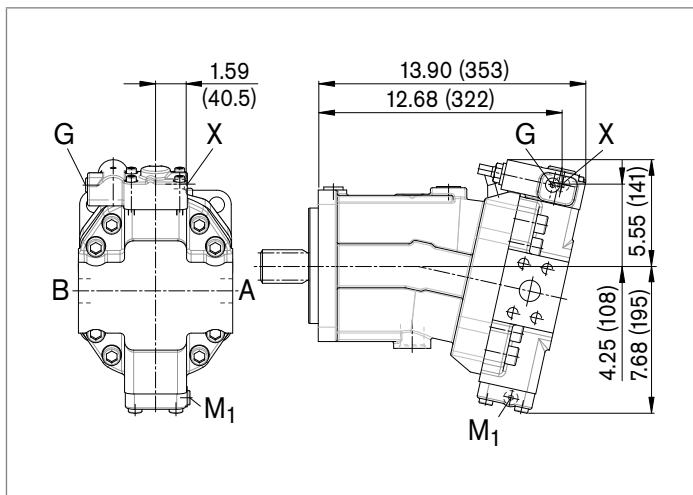

▼ **HZ7** – Hydraulic two-point control,
negative control

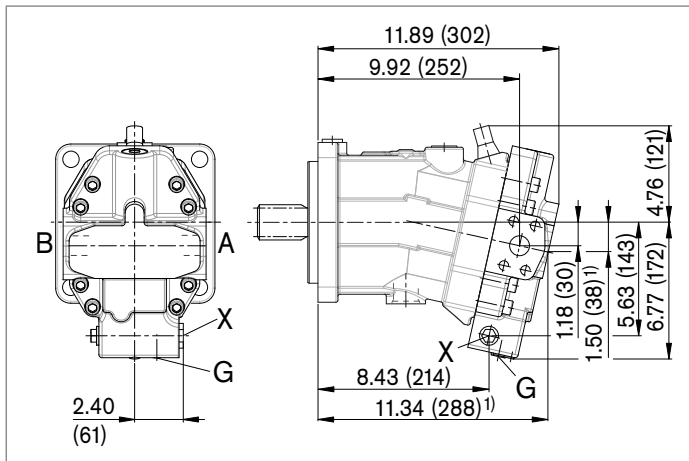

▼ **EZ7, EZ8** – Electric two-point control,
negative control

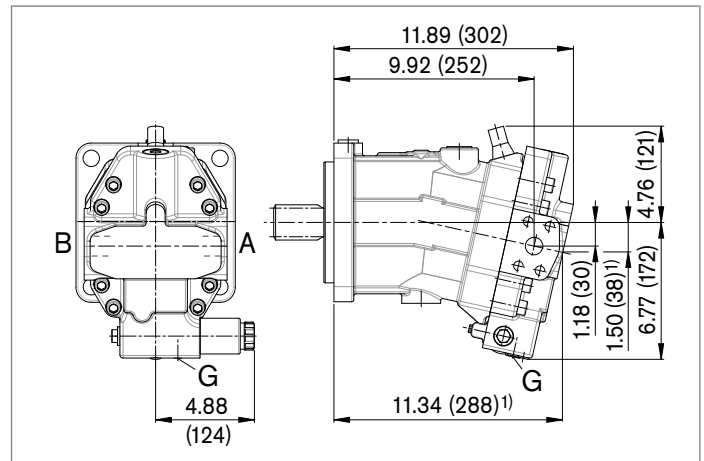

▼ **HA1, HA2 / HA1T3, HA2T3** – Automatic high-pressure-related
control, positive control, with override hydraulic remote controlled,
proportional

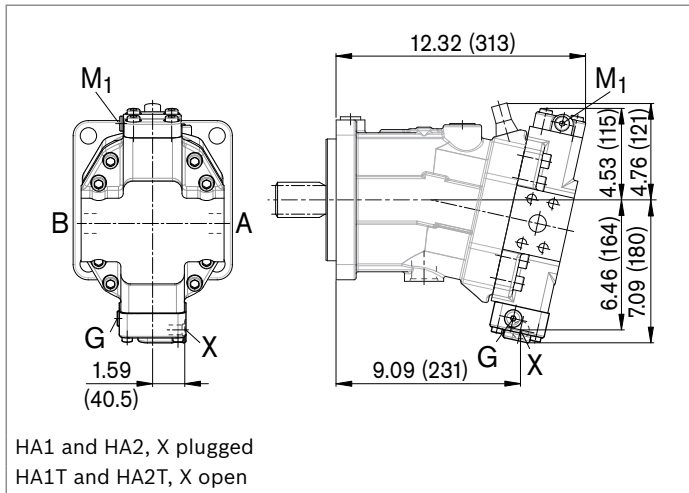

▼ **HA1U1, HA2U2** – Automatic high-pressure-related control,
positive control, with override, electric, two-point

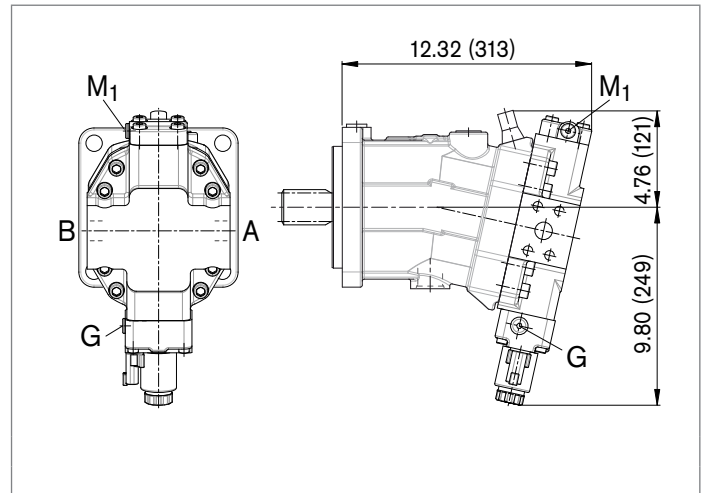

▼ **HA1R1, HA2R2** – Automatic high-pressure-related control,
positive control, with override, electric and travel direction
valve, electric

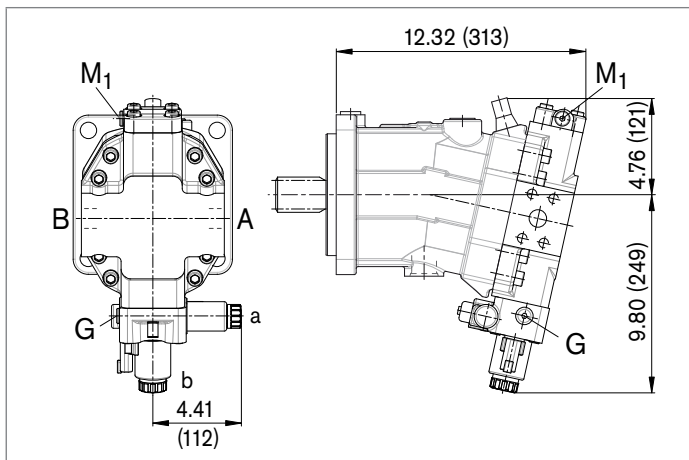

1) Port plate 1 – SAE working ports A and B at rear

▼ **DA0** – Automatic speed-related control, negative control, with hydraulic travel direction valve

▼ **DA1, DA2** – Automatic speed-related control, negative control, with electric travel direction valve and electric $V_{g\max}$ switch

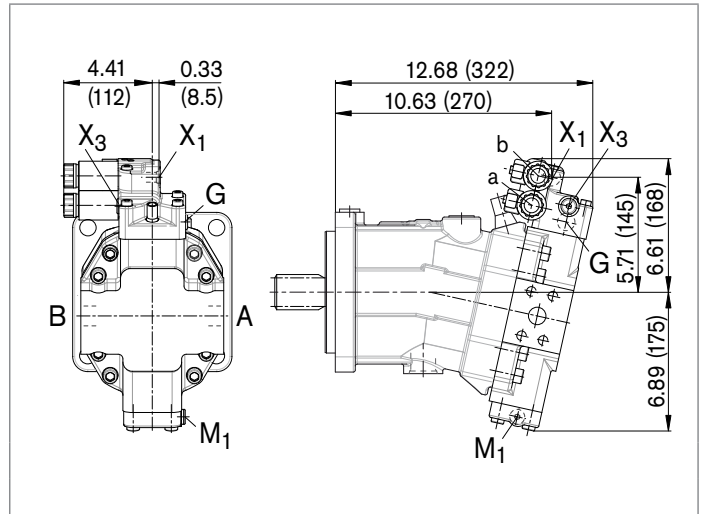
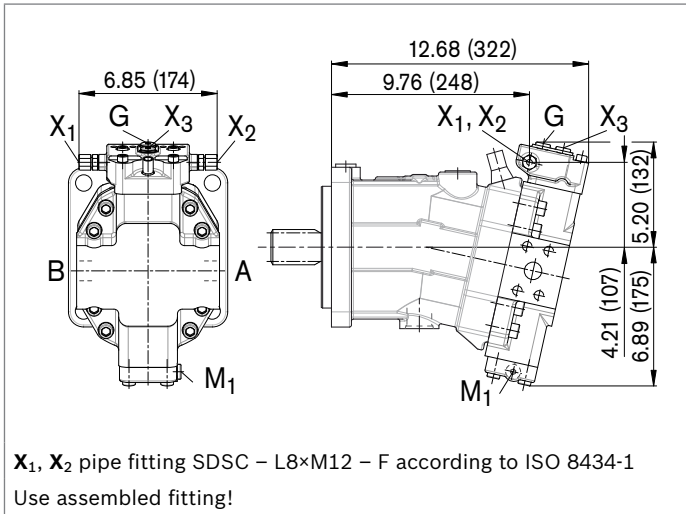

Dimensions size 150

EP5, EP6 – Proportional electric control, negative control

Port plate 2 – SAE working ports **A** and **B** at side, opposite

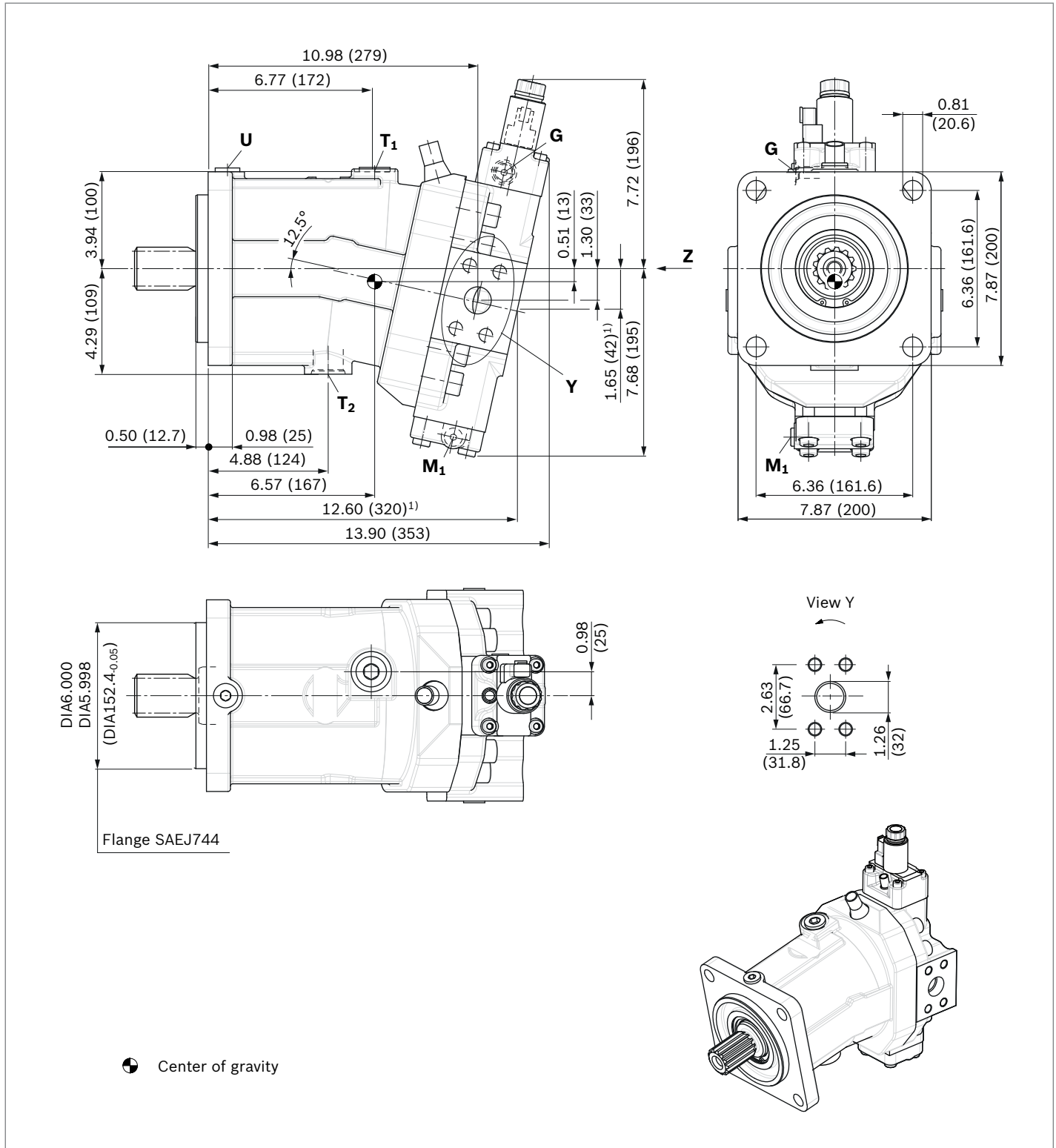

1) Port plate 1 – SAE working ports **A** and **B** at rear

▼ **Location of working ports on port plates (view Z)**

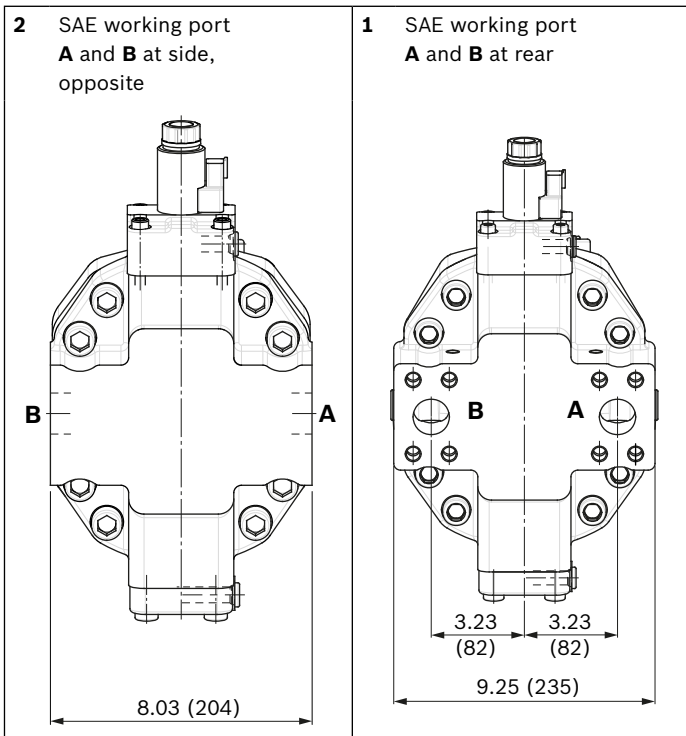

▼ **Splined shaft SAE J744**

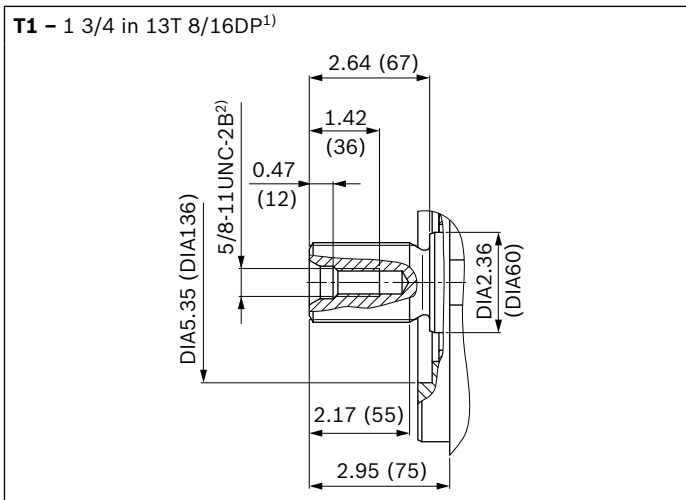

1) Involute toothing acc. to ANSI B92.1a, 30° pressure angle, flat root, side fit, tolerance class 5
 2) Thread according to ASME B1.1

Ports		Standard	Size	p_{max} [psi (bar)] ¹⁾	Status ⁶⁾
A, B ⁴⁾	Working port	SAE J518 ²⁾	1 1/4 in	7250 psi (500 bar)	O
	Mounting bolt A/B, screw grade 8 with hardened washer	ASME B1.1	1/2 in -13 UNC-2B; 0.75 (19) deep		
T ₁	Drain port	ISO 11926 ⁵⁾	1 1/16 in -12 UN-2B; 0.79 (20) deep	45 (3)	X ³⁾
T ₂	Drain port	ISO 11926 ⁵⁾	1 5/16 in -12 UN-2B; 0.79 (20) deep	45 (3)	O ³⁾
G	Synchronous control	ISO 11926 ⁵⁾	9/16 in -18 UNF-2B; 0.51 (13) deep	7250 psi (500 bar)	X
U	Bearing flushing	ISO11926 ⁵⁾	7/8 in -14 UNF-2B; 0.67 (17) deep	45 (3)	X
X	Pilot signal (HP, HZ, HA1T/HA2T)	ISO 11926 ⁵⁾	9/16 in -18 UNF-2B; 0.51 (13) deep	1450 (100)	O
X	Pilot signal (HA1, HA2)	ISO 11926 ⁵⁾	9/16 in -18 UNF-2B; 0.51 (13) deep	45 (3)	X
X ₁ , X ₂	Pilot signal (DA0)	ISO 8434-1	SDSC-L8×M12-F	580 (40)	O
X ₁	Pilot signal (DA1, DA2)	ISO 11926 ⁵⁾	9/16 in -18 UNF-2B; 0.51 (13) deep	580 (40)	O
X ₃	Pilot signal (DA1, DA2)	ISO 11926 ⁵⁾	9/16 in -18 UNF-2B; 0.51 (13) deep	580 (40)	X
M ₁	Measuring stroking chamber	ISO 11926 ⁵⁾	9/16 in -18 UNF-2B; 0.51 (13) deep	7250 psi (500 bar)	X

1) Momentary pressure spikes may occur depending on the application. Keep this in mind when selecting measuring devices and fittings.

2) Only dimensions according to SAE J518.

3) Depending on installation position, T₁ or T₂ must be connected (see also installation instructions on page 72).

4) For the maximum utilization of pressure, only grade 8 screws and hardened washers are to be used to tighten the SAE flange shells.

5) The spot face can be deeper than as specified in the standard.

6) O = Must be connected (plugged on delivery)

X = Plugged (in normal operation)

▼ **EP1, EP2** – Electric proportional control, positive control

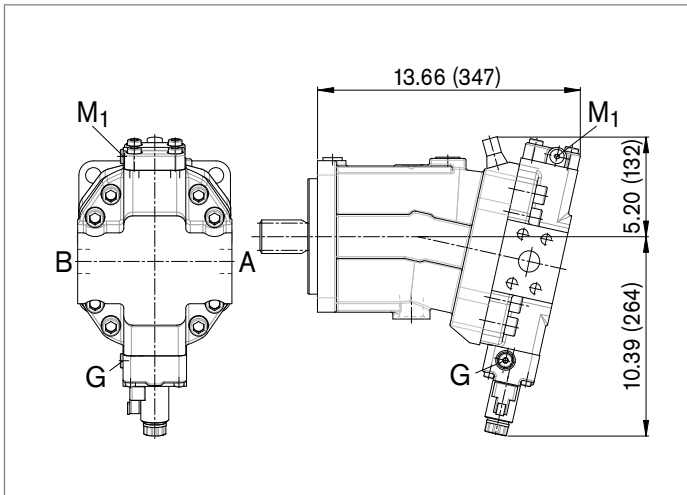

▼ **EP5D1, EP6D1** – Electric proportional control, negative control, with pressure control, fixed setting

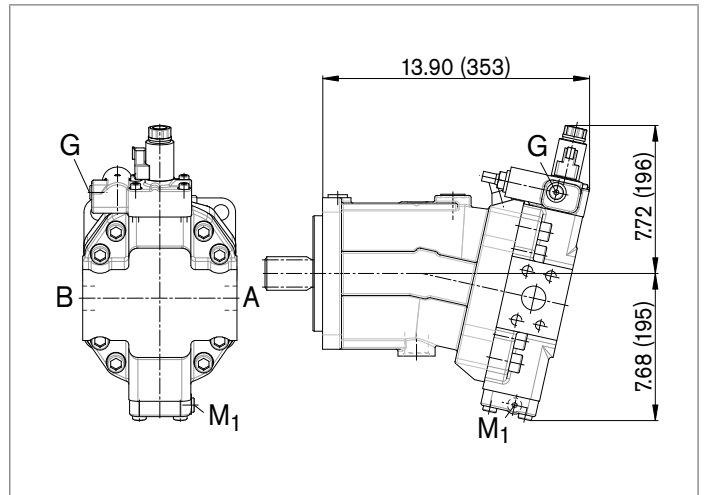

▼ **HP1, HP2** – Hydraulic proportional control, positive control

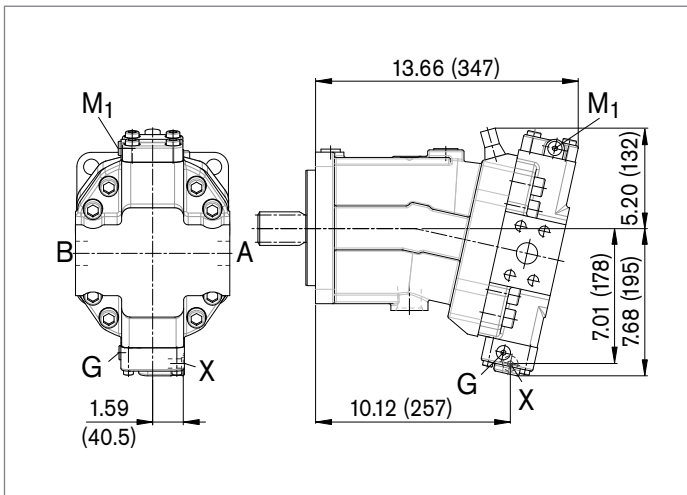

▼ **HP5, HP6** – Hydraulic proportional control, negative control

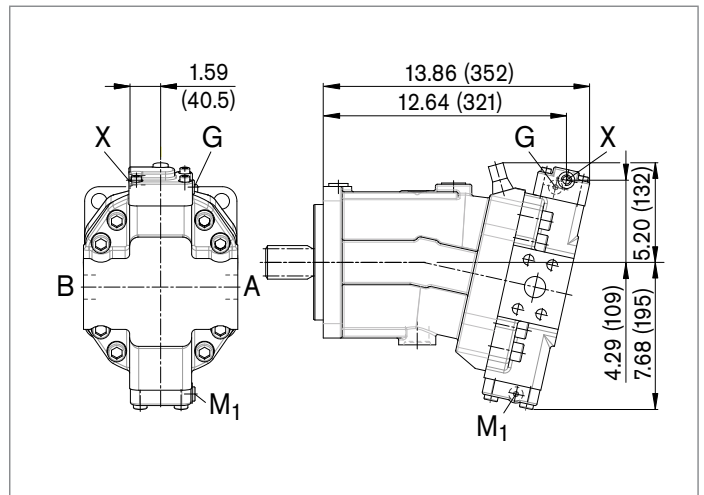

▼ **HP5D1, HP6D1** – Hydraulic proportional control, negative control, with pressure control, fixed setting

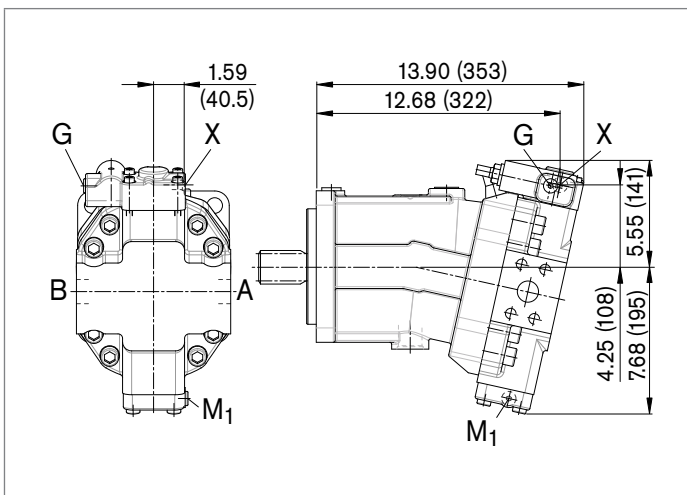

▼ **HZ5** – Hydraulic two-point control,
 negative control

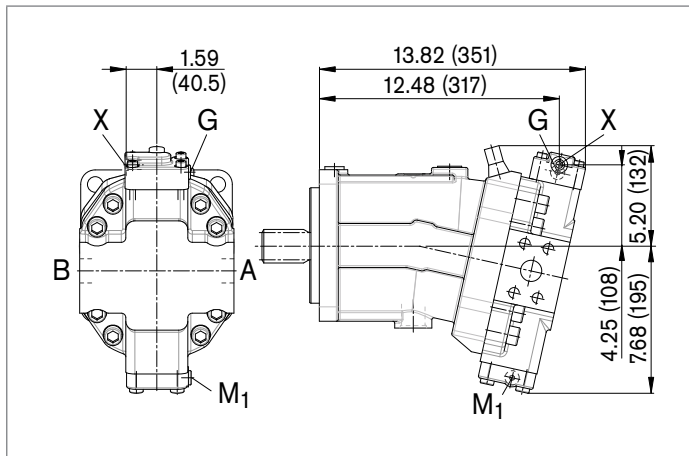

▼ **EZ5, EZ6** – Electric two-point control,
 negative control

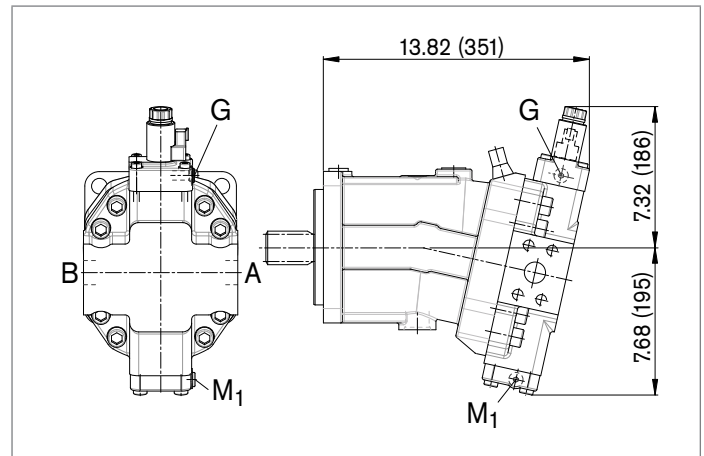

▼ **HA1, HA2 / HA1T3, HA2T3** – Automatic high-pressure-related
 control, positive control, with override hydraulic remote controlled,
 proportional

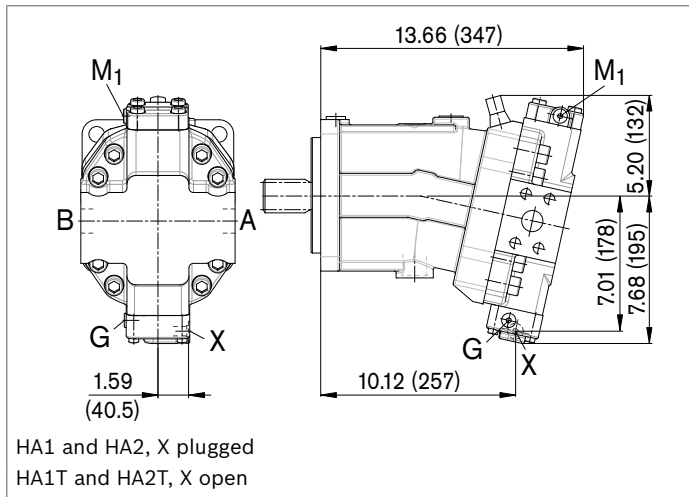

▼ **HA1U1, HA2U2** – Automatic high-pressure-related control,
 positive control, with override, electric, two-point

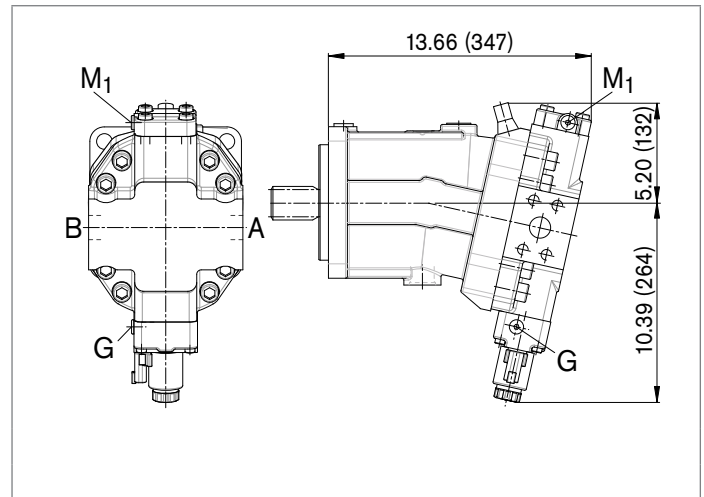

▼ **HA1R1, HA2R2** – Automatic high-pressure-related control,
 positive control, with override, electric and travel direction
 valve, electric

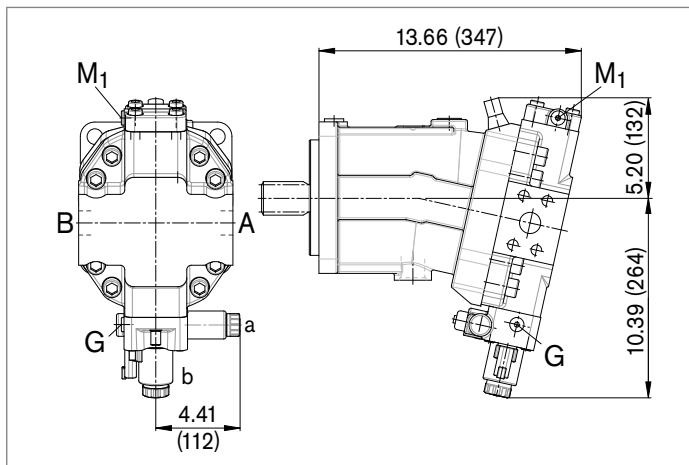

▼ **DA0** – Automatic speed-related control, negative control, with hydraulic travel direction valve

▼ **DA1, DA2** – Automatic speed-related control, negative control, with electric travel direction valve and electric $V_{g\max}$ switch

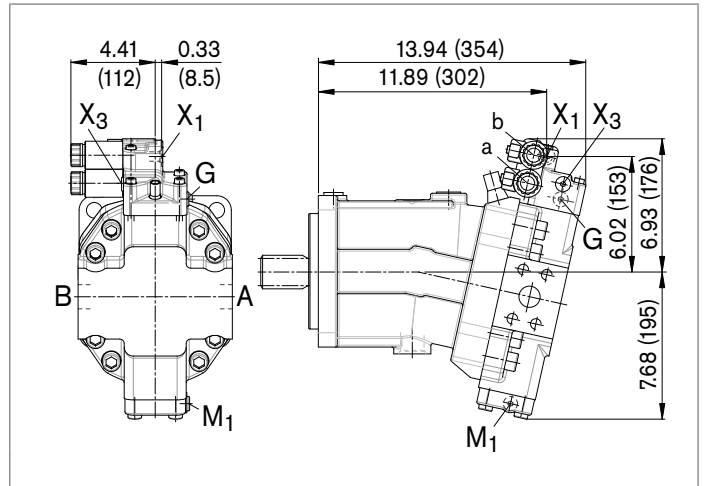
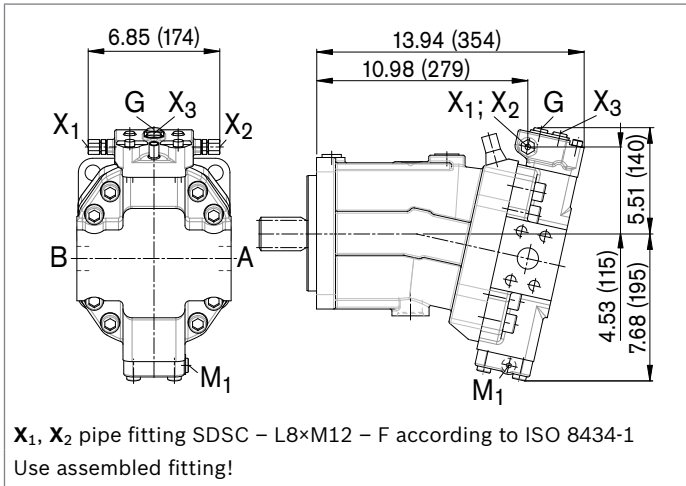

Dimensions size 170

EP5, EP6 – Proportional electric control, negative control

Port plate 2 – SAE working ports **A** and **B** at side, opposite

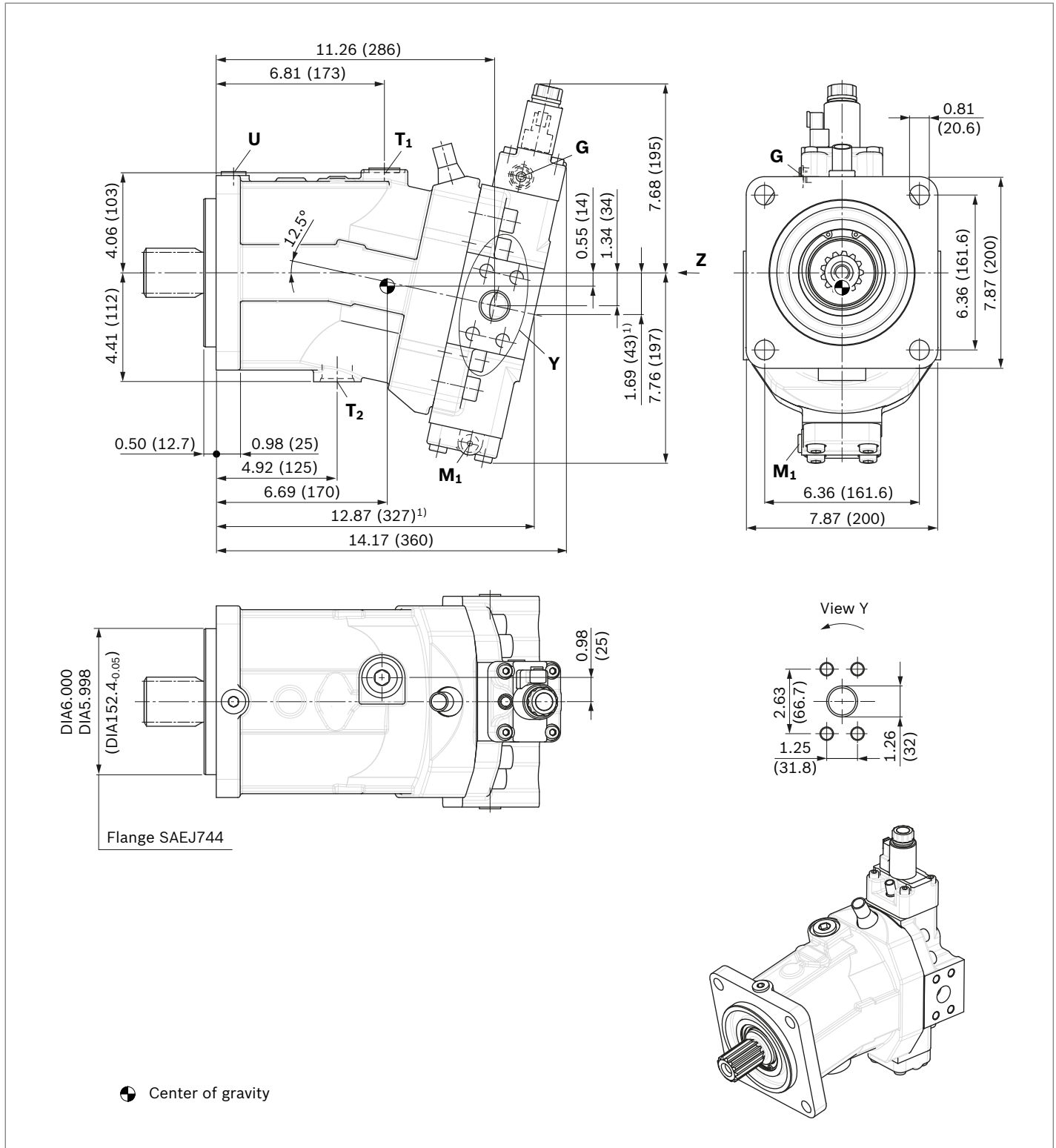

1) Port plate 1 – SAE working ports **A** and **B** at rear

▼ **Location of working ports on port plates (view Z)**

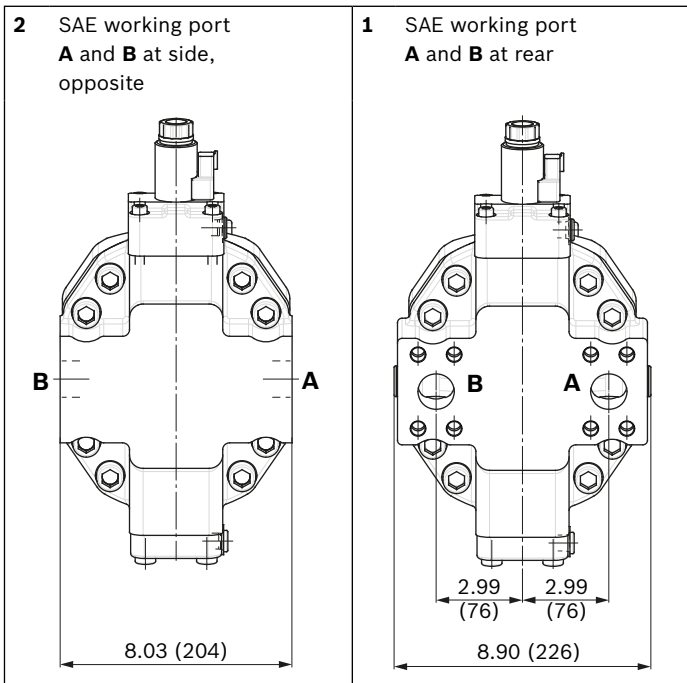

▼ **Splined shaft SAE J744**

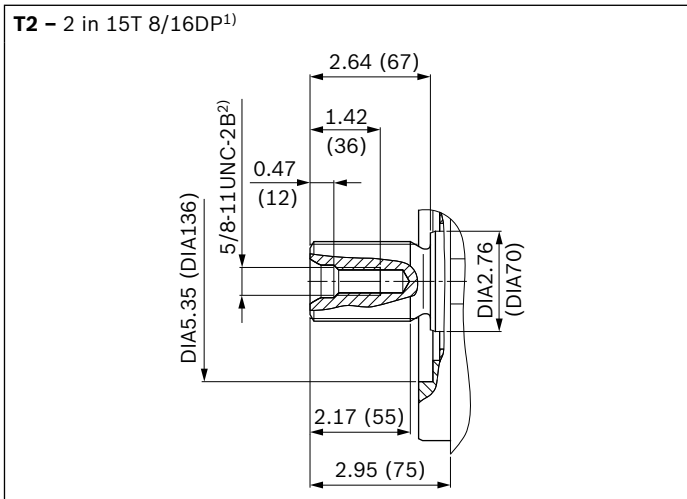

1) Involute toothing acc. to ANSI B92.1a, 30° pressure angle, flat root, side fit, tolerance class 5
 2) Thread according to ASME B1.1

Ports		Standard	Size	p_{max} [psi (bar)] ¹⁾	Status ⁶⁾
A, B ⁴⁾	Working port	SAE J518 ²⁾	1 1/4 in	7250 psi (500 bar)	O
	Mounting bolt A/B, screw grade 8 with hardened washer	ASME B1.1	1/2 in -13 UNC-2B; 0.75 (19) deep		
T ₁	Drain port	ISO 11926 ⁵⁾	1 1/16 in -12 UN-2B; 0.79 (20) deep	45 (3)	X ³⁾
T ₂	Drain port	ISO 11926 ⁵⁾	1 5/16 in -12 UN-2B; 0.79 (20) deep	45 (3)	O ³⁾
G	Synchronous control	ISO 11926 ⁵⁾	9/16 in -18 UNF-2B; 0.51 (13) deep	7250 psi (500 bar)	X
U	Bearing flushing	ISO11926 ⁵⁾	7/8 in -14 UNF-2B; 0.67 (17) deep	45 (3)	X
X	Pilot signal (HP, HZ, HA1T/HA2T)	ISO 11926 ⁵⁾	9/16 in -18 UNF-2B; 0.51 (13) deep	1450 (100)	O
X	Pilot signal (HA1, HA2)	ISO 11926 ⁵⁾	9/16 in -18 UNF-2B; 0.51 (13) deep	45 (3)	X
X ₁ , X ₂	Pilot signal (DA0)	ISO 8434-1	SDSC-L8×M12-F	580 (40)	O
X ₁	Pilot signal (DA1, DA2)	ISO 11926 ⁵⁾	9/16 in -18 UNF-2B; 0.51 (13) deep	580 (40)	O
X ₃	Pilot signal (DA1, DA2)	ISO 11926 ⁵⁾	9/16 in -18 UNF-2B; 0.51 (13) deep	580 (40)	X
M ₁	Measuring stroking chamber	ISO 11926 ⁵⁾	9/16 in -18 UNF-2B; 0.51 (13) deep	7250 psi (500 bar)	X

1) Momentary pressure spikes may occur depending on the application. Keep this in mind when selecting measuring devices and fittings.

2) Only dimensions according to SAE J518.

3) Depending on installation position, T₁ or T₂ must be connected (see also installation instructions on page 72).

4) For the maximum utilization of pressure, only grade 8 screws and hardened washers are to be used to tighten the SAE flange shells.

5) The spot face can be deeper than as specified in the standard.

6) O = Must be connected (plugged on delivery)

X = Plugged (in normal operation)

▼ **EP1, EP2** – Electric proportional control, positive control

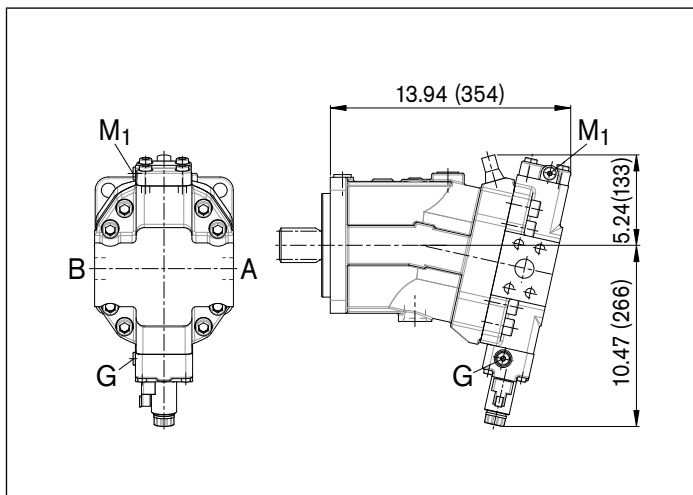

▼ **EP5D1, EP6D1** – Electric proportional control, negative control, with pressure control, fixed setting

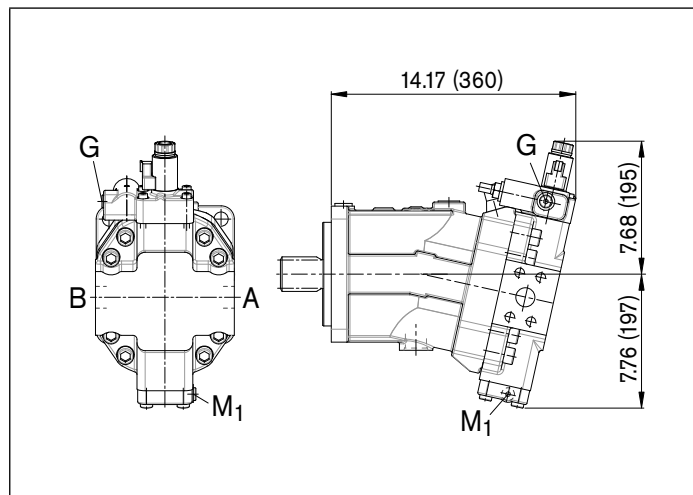

▼ **HP1, HP2** – Hydraulic proportional control, positive control

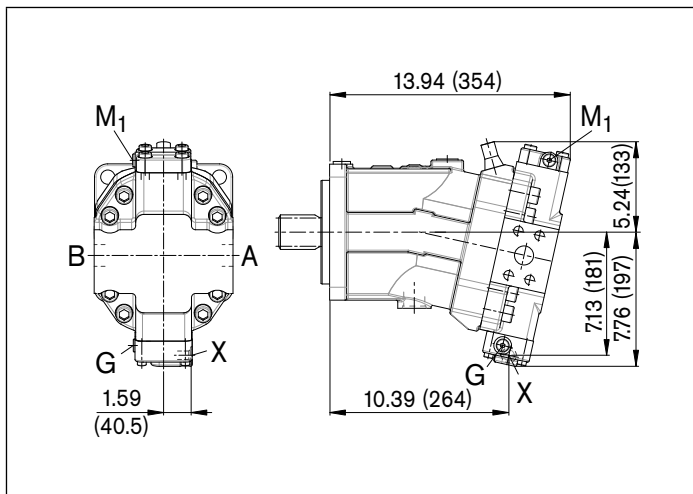

▼ **HP5, HP6** – Hydraulic proportional control, negative control

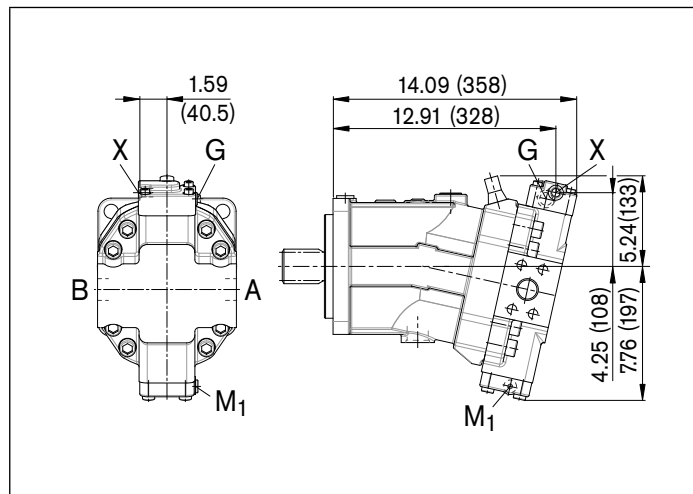

▼ **HP5D1, HP6D1** – Hydraulic proportional control, negative control, with pressure control, fixed setting

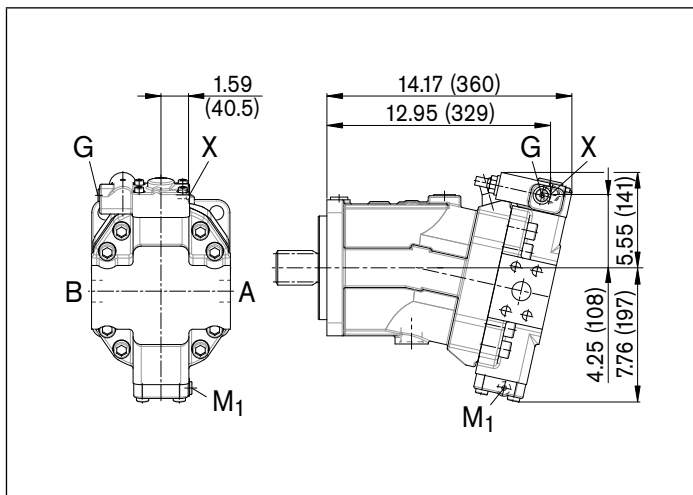

▼ **HZ5** – Hydraulic two-point control,
 negative control

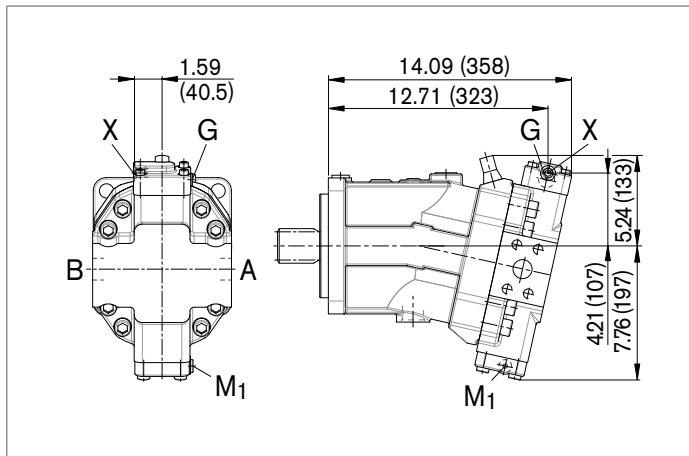

▼ **EZ5, EZ6** – Electric two-point control,
 negative control

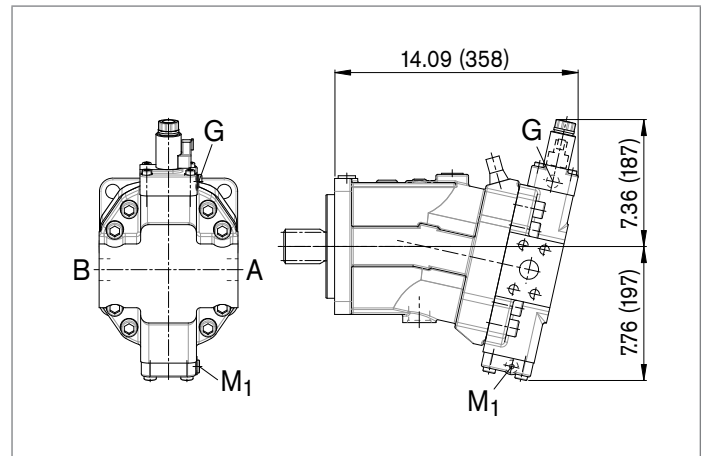

▼ **HA1, HA2 / HA1T3, HA2T3** – Automatic high-pressure-related
 control, positive control, with override hydraulic remote controlled,
 proportional

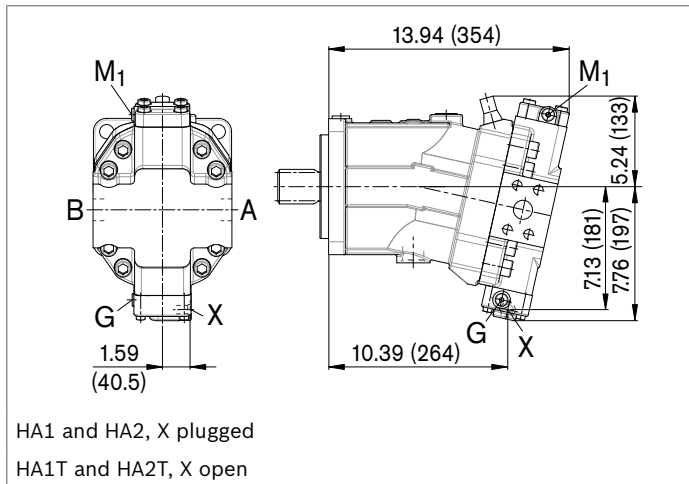

▼ **HA1U1, HA2U2** – Automatic high-pressure-related control,
 positive control, with override, electric, two-point

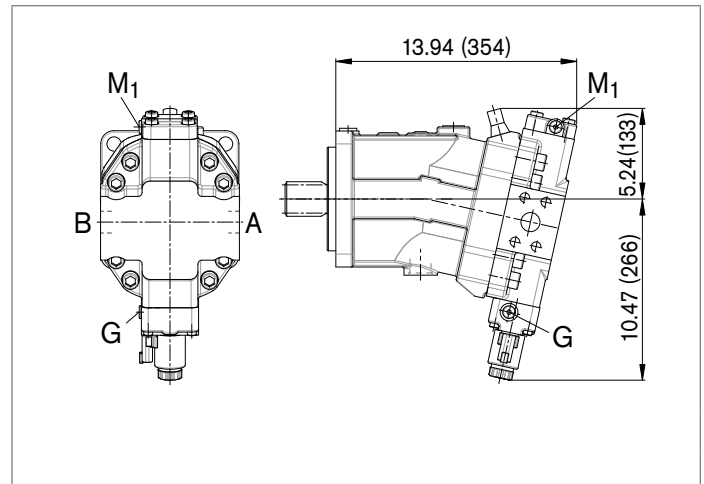

▼ **HA1R1, HA2R2** – Automatic high-pressure-related control,
 positive control, with override, electric and travel direction
 valve, electric

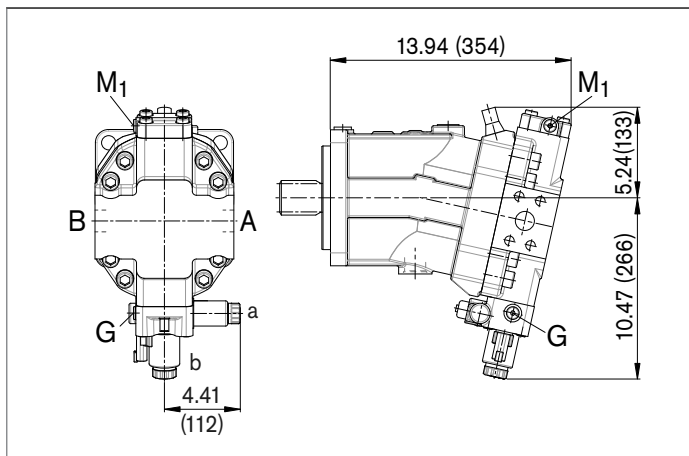

▼ **DA0** – Automatic speed-related control, negative control, with hydraulic travel direction valve

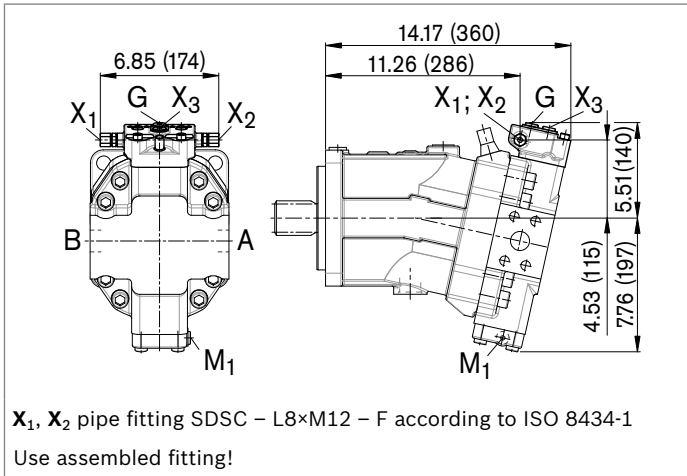

▼ **DA1, DA2** – Automatic speed-related control, negative control, with electric travel direction valve and electric $V_{g\max}$ switch

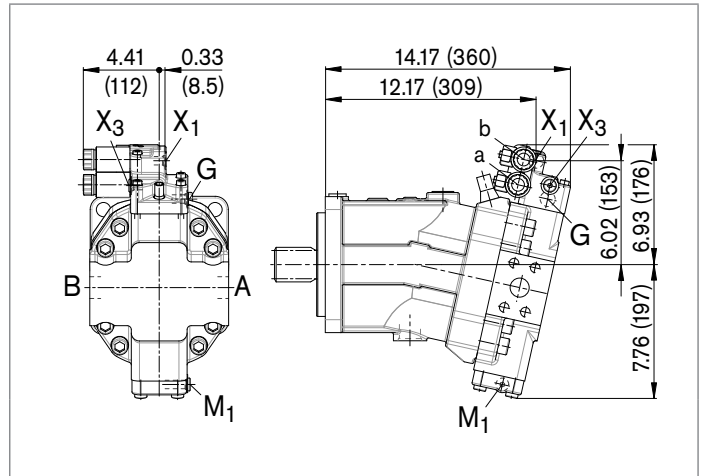

Dimensions size 215

EP5, EP6 – Proportional electric control, negative control

Port plate 2 – SAE working ports **A** and **B** at side, opposite

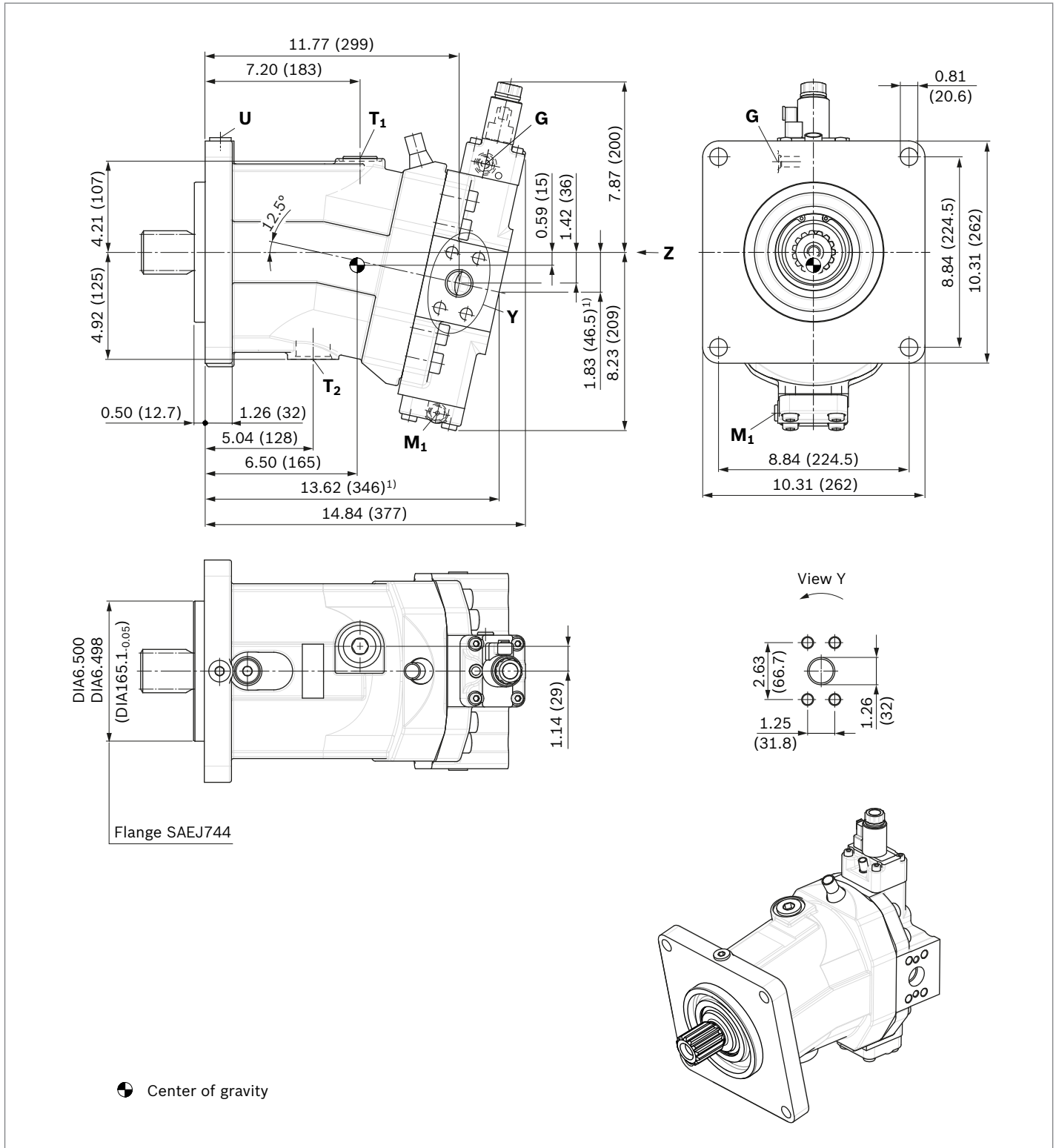

1) Port plate 1 – SAE working ports **A** and **B** at rear

Location of working ports on port plates (view Z)

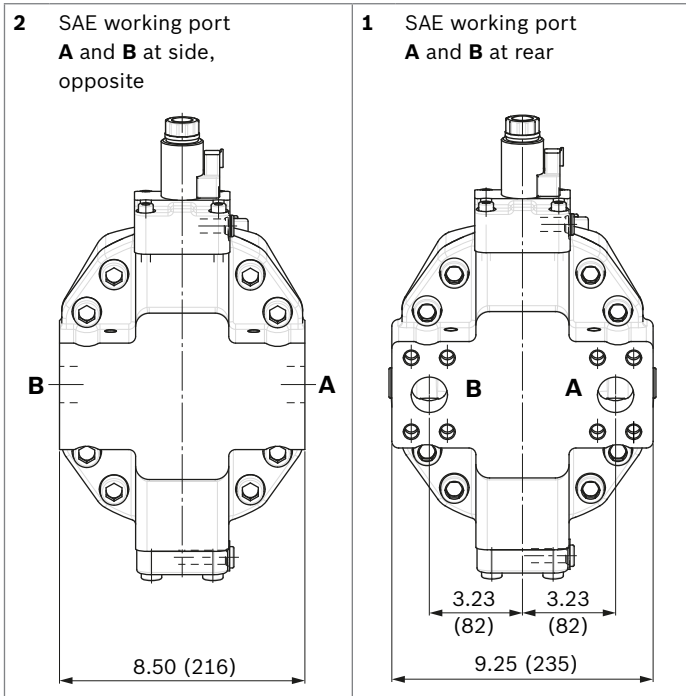

▼ **Splined shaft SAE J744**

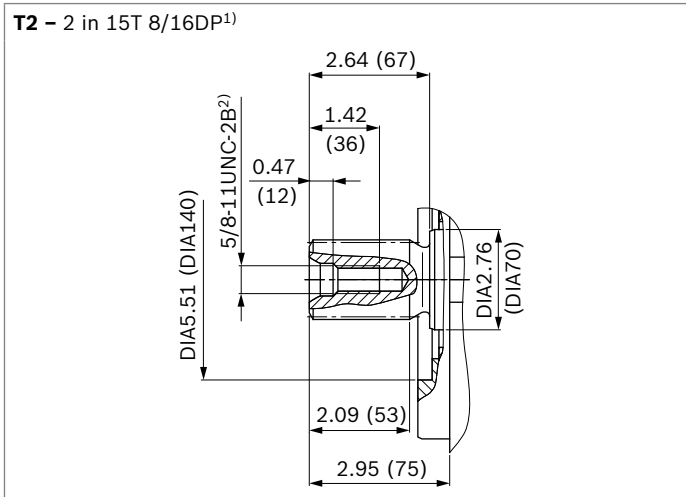

1) Involute toothing acc. to ANSI B92.1a, 30° pressure angle, flat root, side fit, tolerance class 5
 2) Thread according to ASME B1.1

Ports		Standard	Size	p_{max} [psi (bar)] ¹⁾	Status ⁶⁾
A, B ⁴⁾	Working port	SAE J518 ²⁾	1 1/4 in	7250 psi (500 bar)	O
	Mounting bolt A/B, screw grade 8 with hardened washer	ASME B1.1	1/2 in -13 UNC-2B; 0.75 (19) deep		
T ₁	Drain port	ISO 11926 ⁵⁾	1 5/16 in -12 UN-2B; 0.79 (20) deep	45 (3)	X ³⁾
T ₂	Drain port	ISO 11926 ⁵⁾	1 5/8 in -12 UN-2B; 0.79 (20) deep	45 (3)	O ³⁾
G	Synchronous control	ISO 11926 ⁵⁾	9/16 in -18 UNF-2B; 0.51 (13) deep	7250 psi (500 bar)	X
U	Bearing flushing	ISO11926 ⁵⁾	7/8 in -14 UNF-2B; 0.67 (17) deep	45 (3)	X
X	Pilot signal (HP, HZ, HA1T/HA2T)	ISO 11926 ⁵⁾	9/16 in -18 UNF-2B; 0.51 (13) deep	1450 (100)	O
X	Pilot signal (HA1, HA2)	ISO 11926 ⁵⁾	9/16 in -18 UNF-2B; 0.51 (13) deep	45 (3)	X
X ₁ , X ₂	Pilot signal (DA0)	ISO 8434-1	SDSC-L8×M12-F	580 (40)	O
X ₁	Pilot signal (DA1, DA2)	ISO 11926 ⁵⁾	9/16 in -18 UNF-2B; 0.51 (13) deep	580 (40)	O
X ₃	Pilot signal (DA1, DA2)	ISO 11926 ⁵⁾	9/16 in -18 UNF-2B; 0.51 (13) deep	580 (40)	X
M ₁	Measuring stroking chamber	ISO 11926 ⁵⁾	9/16 in -18 UNF-2B; 0.51 (13) deep	7250 psi (500 bar)	X

1) Momentary pressure spikes may occur depending on the application. Keep this in mind when selecting measuring devices and fittings.

2) Only dimensions according to SAE J518.

3) Depending on installation position, T₁ or T₂ must be connected (see also installation instructions on page 72).

4) For the maximum utilization of pressure, only grade 8 screws and hardened washers are to be used to tighten the SAE flange shells.

5) The spot face can be deeper than as specified in the standard.

6) O = Must be connected (plugged on delivery)

X = Plugged (in normal operation)

▼ **EP1, EP2** – Electric proportional control, positive control

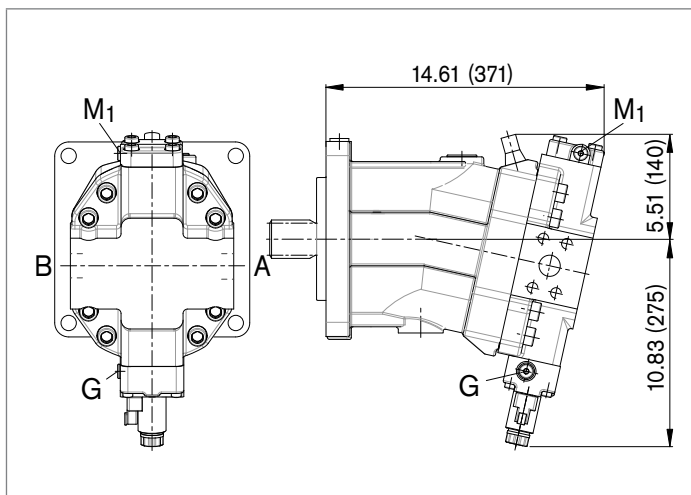

▼ **EP5D1, EP6D1** – Electric proportional control, negative control, with pressure control, fixed setting

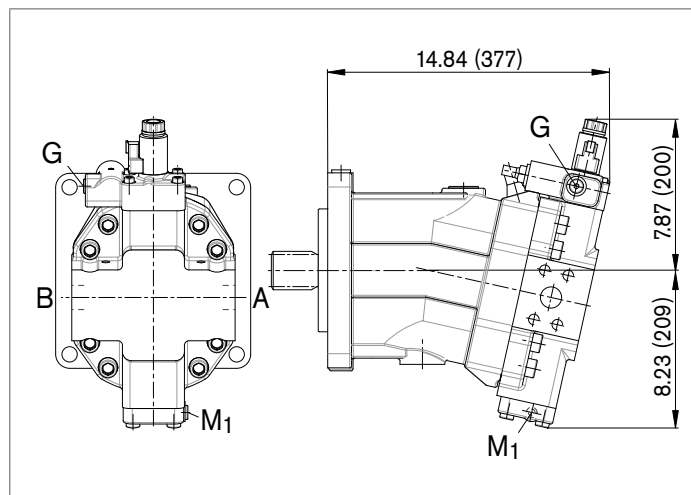

▼ **HP1, HP2** – Hydraulic proportional control, positive control

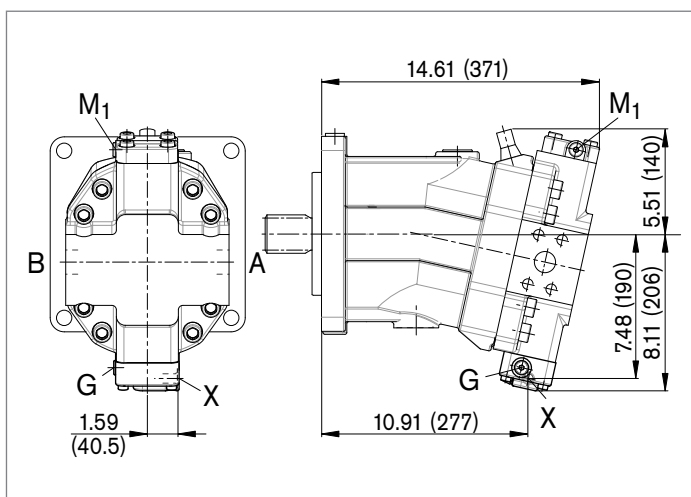

▼ **HP5, HP6** – Hydraulic proportional control, negative control

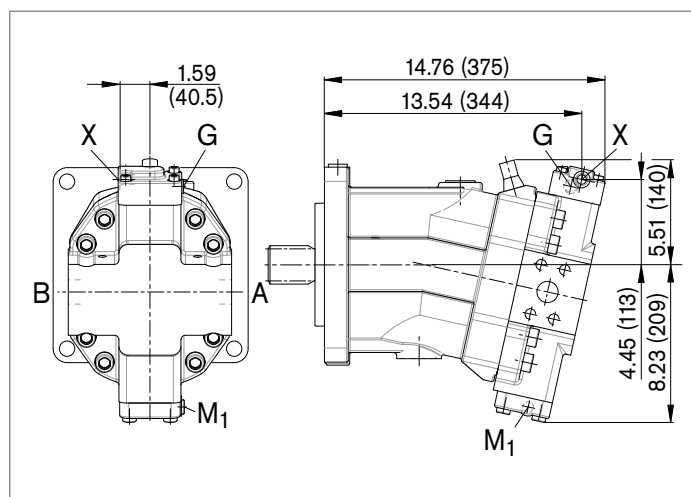

▼ **HP5D1, HP6D1** – Hydraulic proportional control, negative control, with pressure control, fixed setting

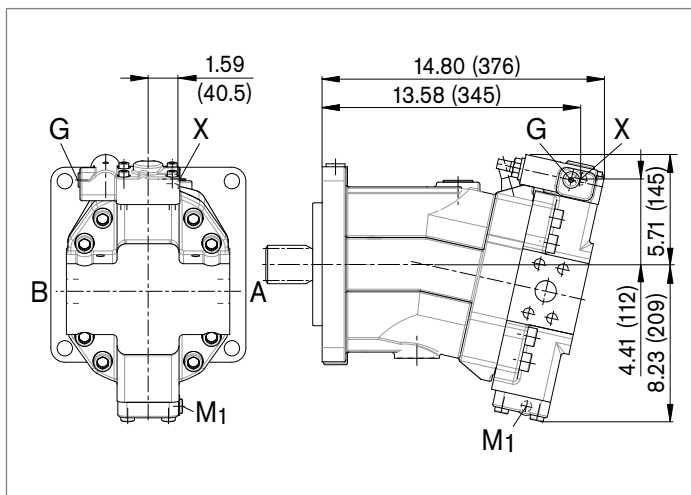

▼ **HZ5** – Hydraulic two-point control,
negative control

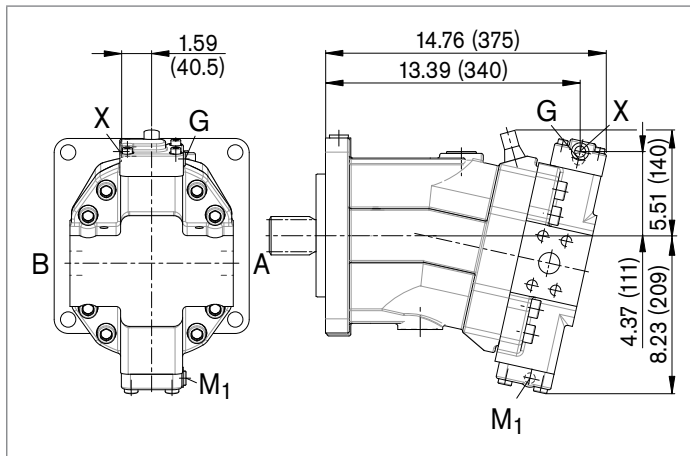

▼ **EZ5, EZ6** – Electric two-point control,
negative control

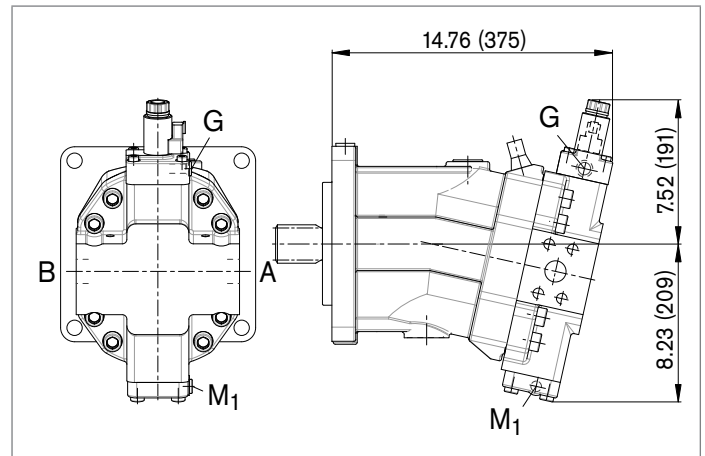

▼ **HA1, HA2 / HA1T3, HA2T3** – Automatic high-pressure-related
control, positive control, with override hydraulic remote controlled,
proportional

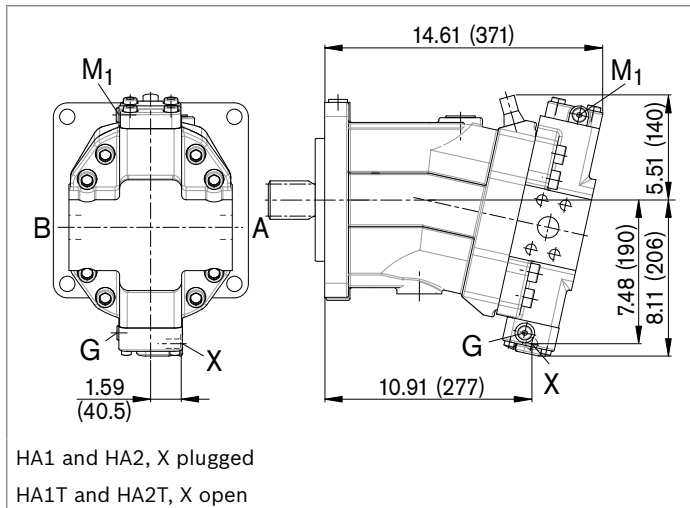

▼ **HA1U1, HA2U2** – Automatic high-pressure-related control,
positive control, with override, electric, two-point

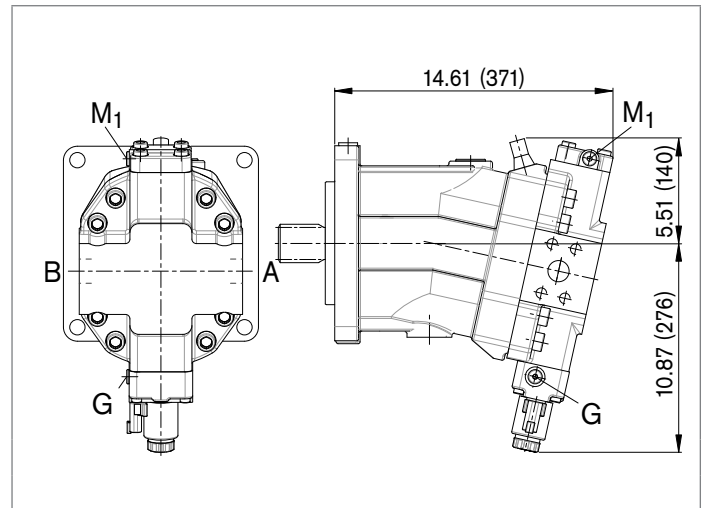

▼ **HA1R1, HA2R2** – Automatic high-pressure-related control,
positive control, with override, electric and travel direction
valve, electric

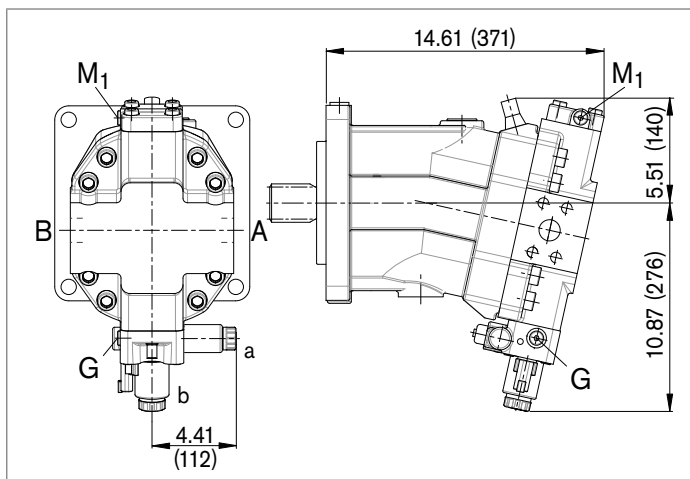

▼ **DA0** – Automatic speed-related control, negative control, with hydraulic travel direction valve

▼ **DA1, DA2** – Automatic speed-related control, negative control, with electric travel direction valve and electric $V_{g\max}$ switch

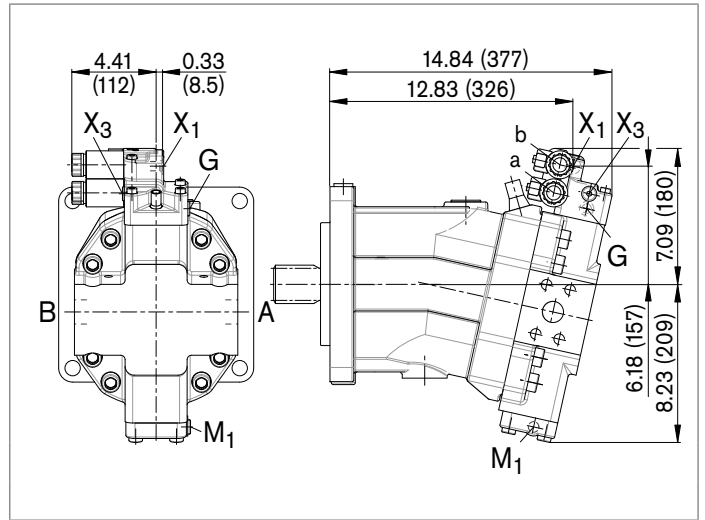
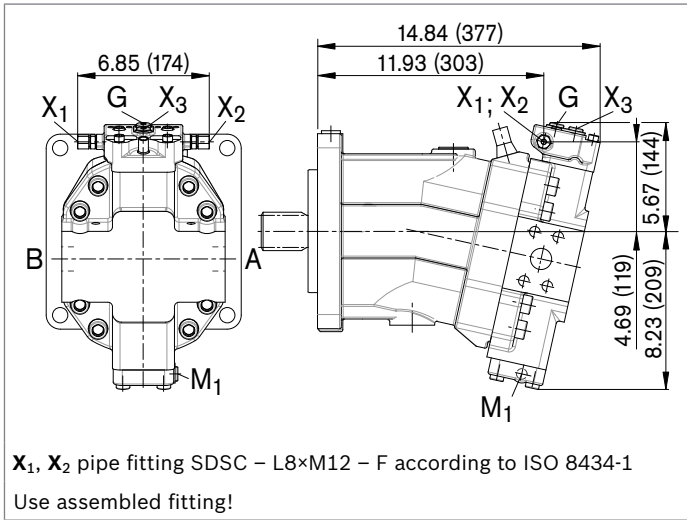

Connector for solenoids

DEUTSCH DT04-2P-EP04

Molded connector, 2-pin, without bidirectional suppressor diode

There is the following type of protection with mounted mating connector:

- ▶ IP67 (DIN/EN 60529) and
- ▶ IP69K (DIN 40050-9)

▼ Circuit symbol

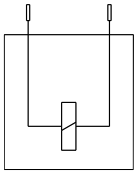

▼ Mating connector DEUTSCH DT06-2S-EP04

Consisting of	DT designation
1 housing	DT06-2S-EP04
1 wedge	W2S
2 sockets	0462-201-16141

The mating connector is not included in the scope of delivery.

This can be supplied by Bosch Rexroth on request (material number R902601804).

Note

- ▶ If necessary, you can change the position of the connector by turning the solenoid.
- ▶ The procedure is defined in the operating instructions.

Flushing and boost pressure valve

The flushing and boost pressure valve is used to remove heat from the hydraulic circuit.

In a closed circuit, it is used for flushing the case and safeguarding the minimum boost pressure.

Hydraulic fluid is directed from the respective low pressure side into the motor housing. This is then fed into the reservoir, together with the leakage. The hydraulic fluid, removed out of the closed circuit must be replaced by cooled hydraulic fluid from the boost pump.

The valve is mounted onto the port plate or integrated (depending on the control type and size).

Cracking pressure of pressure retaining valve

(observe when adjusting the primary valve)

- Sizes 60 to 215, fixed setting 230 psi (16 bar)

Switching pressure of flushing spool Δp

- Sizes 60 to 215 (small flushing valve) 115±15 psi (8±1 bar)
- Sizes 115 to 215 (medium and large flushing valve) 254±22.5 psi (17.5±1.5 bar)

Flushing flow q_v

Orifices can be used to adjust the flushing flows as required. The following information is based on:

$\Delta p_{ND} = p_{ND} - p_G = 365 \text{ psi (25 bar)}$ and $v = 60 \text{ SUS (10 mm}^2/\text{s)}$
(p_{ND} = low pressure, p_G = case pressure)

Small flushing valve for sizes 60 to 115

Material number of orifice	DIA [inch] (ø [mm])	q_v [gpm (l/min)]	Code
R909651766	0.047 (1.2)	0.9 (3.5)	A
R909419695	0.055 (1.4)	1.3 (5)	B
R909419696	0.071 (1.8)	2.1 (8)	C
R909419697	0.079 (2.0)	2.6 (10)	D
R909444361	0.094 (2.4)	3.7 (14)	F

Medium flushing valve for size 115

Material number of orifice	DIA [inch] (ø [mm])	q_v [gpm (l/min)]	Code
R909449997	0.055 (1.4)	1.3 (5)	B
R909449998	0.071 (1.8)	2.1 (8)	C
R909431308	0.079 (2.0)	2.6 (10)	D
R909431309	0.10 (2.5)	3.9 (15)	G
R909431310	0.11 (2.8)	4.8 (18)	I
R902138235	0.12 (3.1)	5.5 (21)	J
R909435172	0.14 (3.5)	7.1 (27)	K
R909436622	0.16 (4.0)	8.2 (31)	L

Large flushing valve for sizes 150 to 215

Material number of orifice	DIA [inch] (ø [mm])	q_v [gpm (l/min)]	Code
R909449997	0.055 (1.4)	1.3 (5)	B
R909449998	0.071 (1.8)	2.1 (8)	C
R909431308	0.079 (2.0)	2.6 (10)	D
R909431309	0.10 (2.5)	3.9 (15)	G
R909431310	0.11 (2.8)	4.8 (18)	I
R902138235	0.12 (3.1)	5.5 (21)	J
R909435172	0.14 (3.5)	7.1 (27)	K
R909436622	0.16 (4.0)	8.2 (31)	L
R909449967	0.20 (5.0)	9.7 (37)	M

▼ Circuit diagram EP

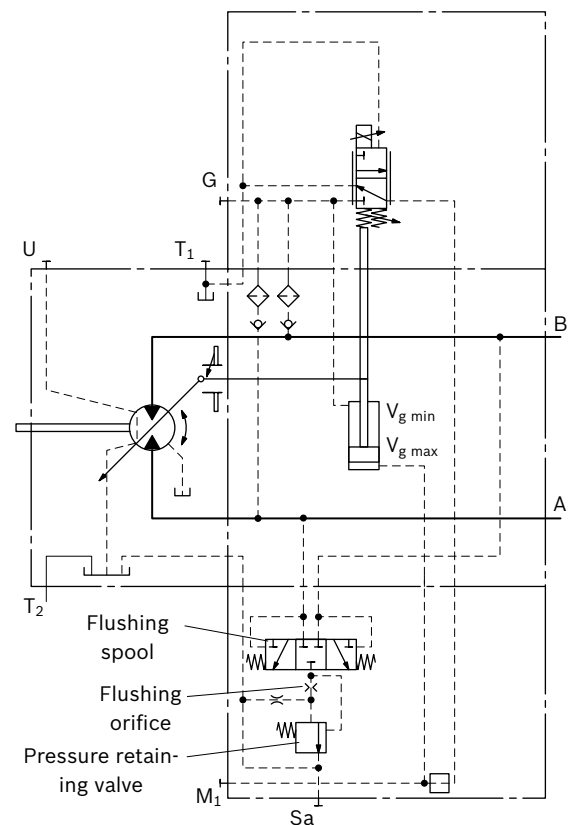

Information

- Port **S_a** only for sizes 150 to 215
- For a flushing flow greater than 9.2 gpm (35 l/min), it is recommended that port **S_a** be connected in order to prevent an increase in case pressure. An increased case pressure reduces the flushing flow.

▼ **Dimensions of sizes 60 to 115 (small flushing valve)**

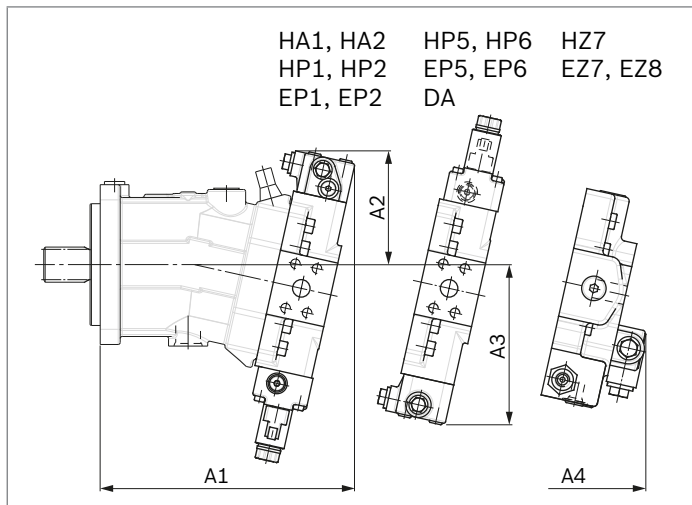

NG	A1	A2	A3	A4
60	10.51 (267)	5.39 (137)	6.93 (176)	10.24 (260)
85	11.69 (297)	5.59 (142)	7.64 (194)	10.94 (278)
115	12.56 (319)	5.63 (143)	7.95 (202)	11.85 (301)

▼ **Dimensions of size 115 (medium flushing valve)**

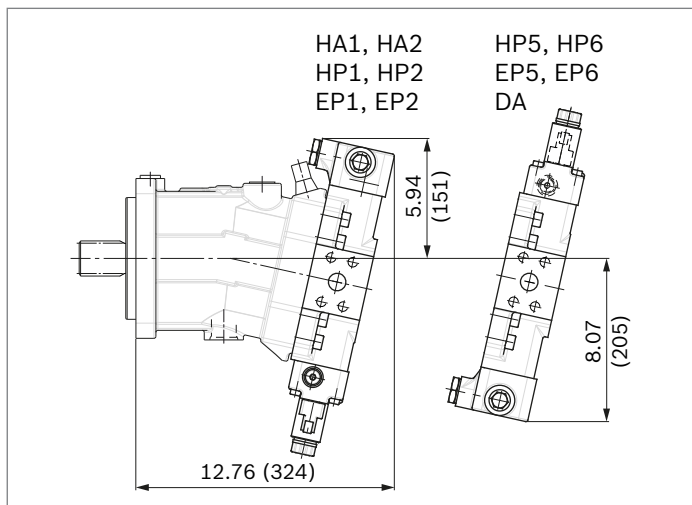

▼ **Dimensions for sizes 150 to 215 (large flushing valve)**

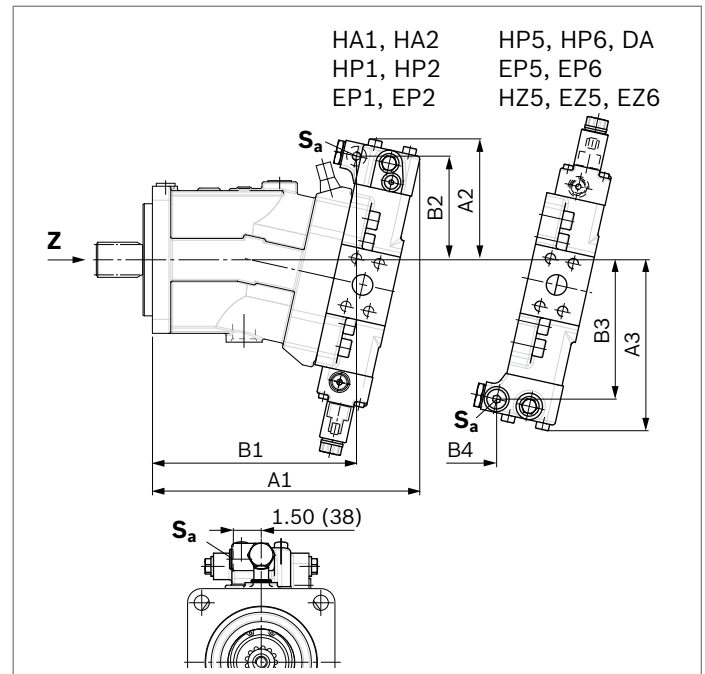

NG	A1	B1	A2	B2	A3	B3	B4
150	14.06 (357)	10.67 (271)	6.50 (165)	5.59 (142)	9.06 (230)	7.36 (187)	7.80 (198)
170	14.33 (364)	10.94 (278)	6.50 (165)	5.59 (142)	9.17 (233)	7.48 (190)	8.03 (204)
215	15.00 (381)	11.61 (295)	6.77 (172)	5.83 (148)	9.61 (244)	7.91 (201)	8.54 (217)

NG	S _a ¹⁾
150	
170	7/8-14UNF-2B; 0.67 (17) deep
215	

1) ISO 11926, ports plugged (in normal operation)
The spot face can be deeper than as specified in the standard.

Counterbalance valve BVD and BVE

Function

Counterbalance valves for drives and winches should reduce the danger of overspeed and cavitation in open circuits of axial piston motors. Cavitation occurs if, during braking, when going downhill or during the load-lowering process, the motor speed is greater than it should be for the given inlet flow and thus the inlet pressure collapses. If the inlet pressure falls below the level specified for the relevant counterbalance valve, the counterbalance valve piston moves into the closed position. The cross-sectional area of the counterbalance valve return duct is then reduced, creating a restriction in the return flow of the hydraulic fluid. The pressure increases and brakes the motor until the speed of the motor reaches the specified value for the given inlet flow.

Note

- ▶ BVD available for sizes 60 to 215 and BVE available for sizes 115 to 215.
- ▶ The BVD counterbalance valve must be ordered additionally. We recommend ordering the counterbalance valve and the motor as a set.

Order example: A6VM085HA1T30004A/71AWV0C2
97W0-0 + BVD20F27S/41B-V03K16D0400S12

- ▶ For safety reasons, controls with beginning of control at $V_{g \min}$ (e.g. HA) are not permissible for winch drives!
- ▶ Counterbalance valves must be optimized during prototype commissioning to prevent unacceptable operating conditions and compliance with the specification must be verified.
- ▶ The counterbalance valve does not replace the mechanical service brake and parking brake.
- ▶ Observe the detailed notes on the BVD counterbalance valve in RE 95522 and BVE counterbalance valve in RE 95525.
- ▶ For the design of the brake release valve, we require the following data for the mechanical holding brake:
 - the cracking pressure
 - the volume of the brake spool between minimum stroke (brake closed) and maximum stroke (brake released with 305 psi (21 bar))
 - the required closing time for a warm device (oil viscosity approx. 69.6 SUS (15 mm²/s))

Permissible input flow or pressure when using DBV and BVD/BVE

Motor NG	Without valve		Limited values when using DBV and BVD/BVE							
	p_{nom}/p_{max} [psi (bar)]	$q_{V \max}$ [gpm (l/min)]	DBV ¹⁾ NG	p_{nom}/p_{max} [psi (bar)]	q_V [gpm (l/min)]	Code	BVD ^{2)/BVE³⁾ NG}	p_{nom}/p_{max} [psi (bar)]	q_V [gpm (l/min)]	Code
60	6500 /7250 (450/500)	73 (276)	22	5100/6100 (350/420)	63 (240)	7	20 (BVD)	5100/6100 (350/420)	58 (220)	7W
85		88 (332)								
115		108 (410)	8		25 (BVD/BVE)	85 (320)	8W			
115		108 (410)								
150		131 (494)								
170		141 (533)								
215		166 (628)	On request							

Mounting of the counterbalance valve

When delivered, the counterbalance valve is mounted to the motor with two tacking screws (transport lock). The tacking screws may not be removed while mounting the working ports. If the counterbalance valve and motor are delivered separately, the counterbalance valve must first be mounted

to the motor port plate using the provided tacking screws. The final mounting of the counterbalance valve on the motor is done with screw fitting of the SAE flange. The screws to be used and the procedure mountings can be found in the instruction manual.

1) Pressure-relief valve
2) Counterbalance valve, double-acting
3) Counterbalance valve, single-acting

Counterbalance valve for travel drive BVD...F

Application option

- ▶ Travel drive for wheeled excavators (BVD and BVE)

▼ **Example schematic for travel drive on wheeled excavators**

A6VM085HA1T30004A/71AWV0C2S97W0-0 + BVD20F27S/41B-V03K16D0400S12

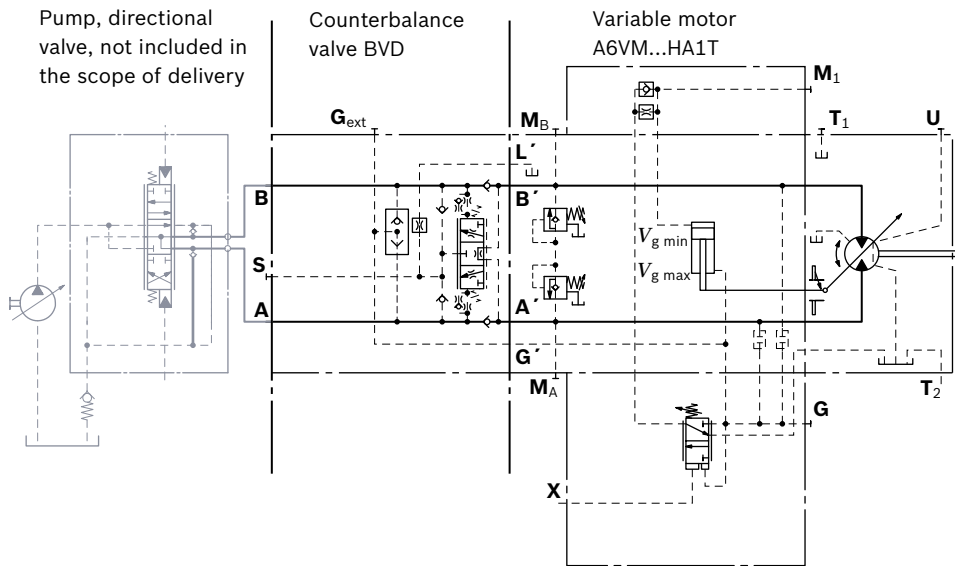

Counterbalance valve for winches and track drives BVD...W and BVE

Application option

- ▶ Winch drives in cranes (BVD and BVE)
- ▶ Track drive in crawler excavators (BVD)

▼ **Example schematic for winch drive in cranes**

A6VM085HP5D10001A/71AWV0C2S97W0-0 + BVE25W38S/51ND-V100K00D4599T30S00-0

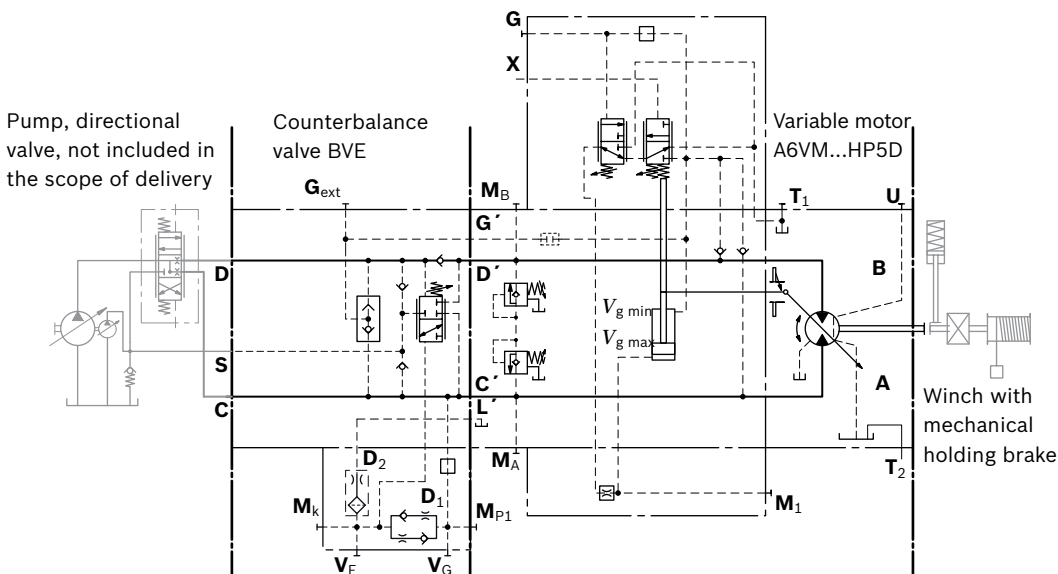

Dimensions

▼ **A6VM...HA, HP1, HP2 and EP1, EP2**

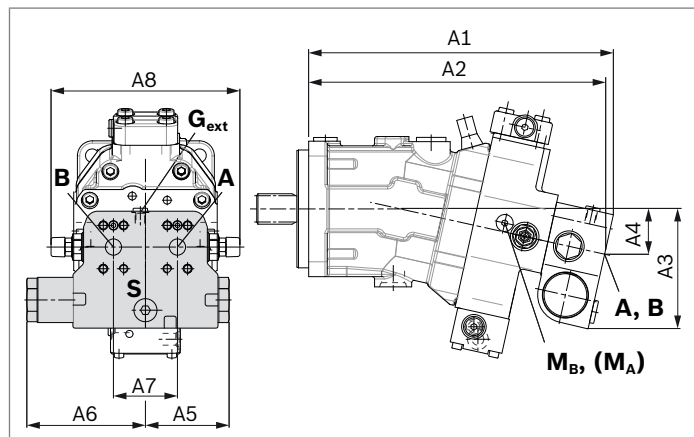

▼ **A6VM...HP5, HP6 and EP5, EP6¹⁾**

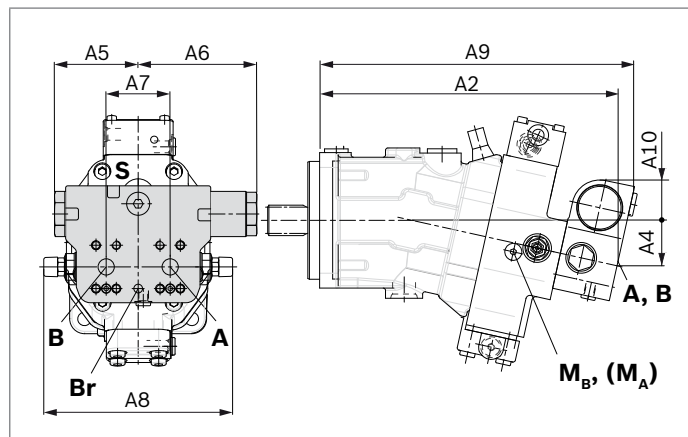

A6VM Counterbalance valve												
NG...plate	Type	Ports A, B	Dimensions									
			A1	A2	A3	A4	A5	A6	A7	A8	A9	A10
60...7	BVD20...17	3/4 in	13.19 (335)	12.83 (326)	5.63 (143)	1.97 (50)	3.86 (98)	5.47 (139)	2.95 (75)	8.74 (222)	13.78 (350)	1.97 (50)
85...7	BVD20...27	1 in	14.33 (364)	13.98 (355)	5.83 (148)	2.17 (55)	3.86 (98)	5.47 (139)	2.95 (75)	8.74 (222)	14.92 (379)	1.81 (46)
115...7	BVD20...28	1 in	15.51 (394)	15.16 (385)	5.98 (152)	2.32 (59)	3.86 (98)	5.47 (139)	3.31 (84)	9.21 (234)	16.10 (409)	1.61 (41)
115...8	BVD25...38	1 1/4 in	16.22 (412)	15.83 (402)	6.50 (165)	2.48 (63)	4.74 (120.5)	6.89 (175)	3.31 (84)	9.37 (238)	16.81 (427)	2.20 (56)
150...8	BVD25...38	1 1/4 in	17.44 (443)	17.01 (433)	6.61 (168)	2.64 (67)	4.74 (120.5)	6.89 (175)	3.31 (84)	9.37 (238)	18.03 (458)	2.09 (53)
170...8	BVD25...38	1 1/4 in	17.68 (449)	17.28 (439)	6.69 (170)	2.68 (68)	4.74 (120.5)	6.89 (175)	3.31 (84)	9.37 (238)	18.27 (464)	2.01 (51)
215...8	BVD25...38	1 1/4 in	18.90 (480)	18.50 (470)	6.93 (176)	2.91 (74)	4.74 (120.5)	6.89 (175)	3.31 (84)	11.77 (299)	19.49 (495)	1.81 (46)
115...8	BVE25...38	1 1/4 in	16.22 (412)	15.83 (402)	6.73 (171)	2.48 (63)	5.39 (137)	8.43 (214)	3.31 (84)	9.37 (238)	16.89 (429)	2.48 (63)
150...8	BVE25...38	1 1/4 in	17.44 (443)	17.01 (433)	6.89 (175)	2.64 (67)	5.39 (137)	8.43 (214)	3.31 (84)	9.37 (238)	17.91 (455)	2.32 (59)
170...8	BVE25...38	1 1/4 in	17.68 (449)	17.28 (439)	6.93 (176)	2.68 (68)	5.39 (137)	8.43 (214)	3.31 (84)	9.37 (238)	18.27 (464)	2.32 (59)
215...8	BVE25...38	1 1/4 in	18.90 (480)	18.50 (470)	7.17 (182)	2.91 (74)	5.39 (137)	8.43 (214)	3.31 (84)	11.77 (299)	19.49 (495)	2.05 (52)

Ports	Version	A6VM plate	Standard	Size	$p_{max perm}$ [psi (bar)] ²⁾	Status		
A, B	Working line		SAE J518	see table above	6100 (420)	O		
S	Infeed	BVD20	DIN 3852 ³⁾	M22 × 1.5; 14 deep	435 (30)	X		
		BVD25, BVE25	DIN 3852 ³⁾	M27 × 2; 16 deep	435 (30)	X		
B_r	Brake release, reduced high pressure	L		7	DIN 3852 ³⁾	M12 × 1.5; 12.5 deep	435 (30)	O
				8	DIN 3852 ³⁾	M12 × 1.5; 12 deep	435 (30)	O
G_{ext}	Brake release, high pressure	S			DIN 3852 ³⁾	M12 × 1.5; 12.5 deep	6100 (420)	X
M_A, M_B	Measuring pressure A and B				ISO 6149 ³⁾	M18 × 1.5; 14.5 deep	6100 (420)	X

1) At the mounting version for the controls HP5, HP6 and EP5, EP6, the cast-in port designations **A** and **B** on the counterbalance valve BVD do not correspond with the connection drawing of the A6VM motor. The designation of the ports on the installation drawing of the motor is binding!

2) Momentary pressure spikes may occur depending on the application. Keep this in mind when selecting measuring devices and fittings.
3) The spot face can be deeper than as specified in the standard.
O = Must be connected (plugged on delivery)
X = Plugged (in normal operation)

Mounting the counterbalance valve

When delivered, the counterbalance valve is mounted to the motor with two tacking screws (transport lock). The tacking screws may not be removed while mounting the working ports! If the counterbalance valve and motor are delivered separately, the counterbalance valve must first be mounted to the motor port plate using the provided tacking screws.

The final mounting of the counterbalance valve on the motor is done with screw fitting of the SAE flange.

The screws to be used and the procedure mounting can be found in the instruction manual.

Speed sensor

Version A6VM...U ("prepared for speed sensor", i.e. without sensor) is equipped with a spline on the rotary group.

A signal proportional to motor speed can be generated with the fitted DSA/DSM speed sensor. The DSA/DSM sensor registers the speed and direction of rotation.

Ordering code, technical data, dimensions and details on the connector, plus safety instructions about the sensor can be found in the relevant data sheet (95132 for DSM, 95133 for DSA).

The sensor is mounted on the port provided for this purpose with a mounting bolt. On deliveries without sensor, the port is plugged with a pressure-resistant cover.

We recommend ordering the A6VM variable motor complete with mounted sensor.

▼ Circuit diagram EP

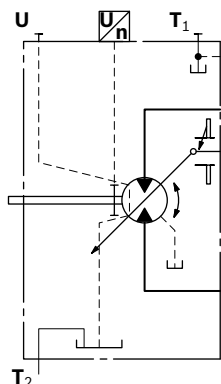

▼ Dimensions

"V" design with mounted speed sensor

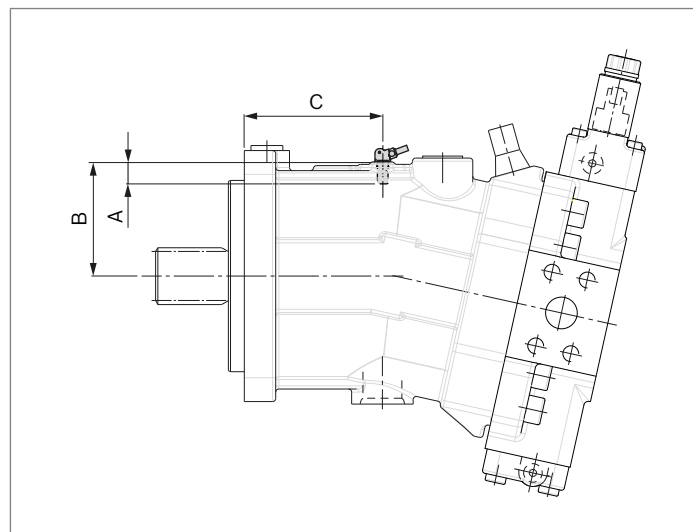

Size	60	85	115	150	170	215
Number of teeth	54	58	67	72	75	80
A Insertion depth (tolerance -0.0098 (-0.25))	0.72 (18.4)	0.72 (18.4)	0.72 (18.4)	0.72 (18.4)	0.72 (18.4)	0.72 (18.4)
B Contact surface	2.95 (75)	3.11 (79)	3.46 (88)	3.66 (93)	3.78 (96)	3.98 (101)
C	3.55 (90.2)	3.91 (99.2)	4.30 (109.2)	4.85 (123.7)	4.87 (123.7)	5.01 (127.2)

Setting range for displacement

	60				85				115			
	$V_{g \max}$ [in ³ /rev (cm ³ /rev)]		$V_{g \min}$ [in ³ /rev (cm ³ /rev)]		$V_{g \max}$ [in ³ /rev (cm ³ /rev)]		$V_{g \min}$ [in ³ /rev (cm ³ /rev)]		$V_{g \max}$ [in ³ /rev (cm ³ /rev)]		$V_{g \min}$ [in ³ /rev (cm ³ /rev)]	
	from	to	from	to	from	to	from	to	from	to	from	to
A	3.78 (62.0)	3.78 (62.0)	0.0 (0.0)	0.92 (15.0)	3.35 (85.2)	3.35 (85.2)	0.0 (0.0)	0.55 (9.0)	7.05 (115.6)	7.05 (115.6)	0.0 (0.0)	1.46 (24.0)
	without screw		M10 × 60 R909154690		without screw		M12 × 60 R909083530		without screw		M12 × 70 R909085976	
B	3.78 (62.0)	3.78 (62.0)	> 0.92 (> 15.0)	1.86 (30.5)	3.35 (85.2)	3.35 (85.2)	> 0.55 (> 9.0)	1.71 (28.0)	7.05 (115.6)	7.05 (115.6)	> 1.46 (> 24.0)	2.90 (47.5)
	without screw		M10 × 70 R909153779		without screw		M12 × 70 R909085976		without screw		M12 × 80 R909153075	
C	3.78 (62.0)	3.78 (62.0)	> 1.86 (> 30.5)	2.62 (43.0)	3.35 (85.2)	3.35 (85.2)	> 1.71 (> 28.00)	2.87 (47.0)	7.05 (115.6)	7.05 (115.6)	> 2.90 (> 47.5)	4.33 (71.0)
	without screw		M10 × 80 R909154058		without screw		M12 × 80 R909153075		without screw		M12 × 90 R909154041	
D	x		x		3.35 (85.2)	3.35 (85.2)	> 2.87 (> 47.0)	3.60 (59.0)	7.05 (115.6)	7.05 (115.6)	> 4.33 (> 71.0)	4.88 (80.0)
	without screw		without screw		without screw		M12 × 90 R909154041		without screw		M12 × 100 R909153975	
E	< 3.78 (< 62.0)	2.90 (47.5)	0.0 (0.0)	0.92 (15.0)	3.35 (85.2)	3.03 (77.0)	0.0 (0.0)	0.55 (9.0)	< 7.05 (< 115.6)	5.71 (93.5)	0.0 (0.0)	1.46 (24.0)
	M10 × 60 R909154690		M10 × 60 R909154690		M12 × 60 R909083530		M12 × 60 R909083530		M12 × 70 R909085976		M12 × 70 R909085976	
F	< 3.78 (< 62.0)	2.90 (47.5)	> 0.92 (> 15.0)	1.86 (30.5)	3.35 (85.2)	3.03 (77.0)	> 0.55 (> 9.0)	1.71 (28.0)	< 7.05 (< 115.6)	5.71 (93.5)	> 1.46 (> 24.0)	2.90 (47.5)
	M10 × 60 R909154690		M10 × 70 R909153779		M12 × 60 R909083530		M12 × 70 R909085976		M12 × 70 R909085976		M12 × 80 R909153075	
G	< 3.78 (< 62.0)	2.90 (47.5)	> 1.86 (> 30.5)	2.62 (43.0)	3.35 (85.2)	3.03 (77.0)	> 1.71 (> 28.00)	2.87 (47.0)	< 7.05 (< 115.6)	5.71 (93.5)	> 2.90 (> 47.5)	4.33 (71.0)
	M10 × 60 R909154690		M10 × 80 R909154058		M12 × 60 R909083530		M12 × 80 R909153075		M12 × 70 R909085976		M12 × 90 R909154041	
H	x		x		3.35 (85.2)	3.03 (77.0)	> 2.87 (> 47.0)	3.60 (59.0)	< 7.05 (< 115.6)	5.71 (93.5)	> 4.33 (> 71.0)	4.88 (80.0)
	without screw		without screw		without screw		M12 × 60 R909083530		without screw		M12 × 100 R909153975	
J	< 2.90 (< 47.5)	2.01 (33.0)	0.0 (0.0)	0.92 (15.0)	< 3.03 (< 77.0)	2.28 (58.0)	0.0 (0.0)	0.55 (9.0)	< 5.71 (< 93.5)	4.33 (71.0)	0.0	1.46 (24.0)
	M10 × 70 R909153779		M10 × 60 R909154690		M12 × 70 R909085976		M12 × 60 R909083530		M12 × 80 R909153075		M12 × 70 R909085976	
K	< 2.90 (< 47.5)	2.01 (33.0)	> 0.92 (> 15.0)	1.86 (30.5)	< 3.03 (< 77.0)	2.28 (58.0)	> 0.55 (> 9.0)	1.71 (28.0)	< 5.71 (< 93.5)	4.33 (71.0)	> 1.46 (> 24.0)	2.90 (47.5)
	M10 × 70 R909153779		M10 × 70 R909153779		M12 × 70 R909085976		M12 × 70 R909085976		M12 × 80 R909153075		M12 × 80 R909153075	
L	< 2.90 (< 47.5)	2.01 (33.0)	> 1.86 (> 30.5)	2.62 (43.0)	< 3.03 (< 77.0)	2.28 (58.0)	> 1.71 (> 28.00)	2.87 (47.0)	< 5.71 (< 93.5)	4.33 (71.0)	> 2.90 (> 47.5)	4.33 (71.0)
	M10 × 70 R909153779		M10 × 80 R909154058		M12 × 70 R909085976		M12 × 80 R909153075		M12 × 80 R909153075		M12 × 90 R909154041	
M	x		x		< 3.03 (< 77.0)	2.28 (58.0)	> 2.87 (> 47.0)	3.60 (59.0)	< 5.71 (< 93.5)	4.33 (71.0)	> 4.33 (> 71.0)	4.88 (80.0)
	without screw		without screw		without screw		M12 × 70 R909085976		without screw		M12 × 100 R909153975	

Specify exact settings for $V_{g \min}$ and $V_{g \max}$ in plain text when ordering: $V_{g \min} = \dots \text{ in}^3 \text{ (cm}^3\text{)}$, $V_{g \max} = \dots \text{ in}^3 \text{ (cm}^3\text{)}$

Theoretical, maximum setting: ► for $V_{g \min} = 0.7 \times V_{g \max}$

► for $V_{g \max} = 0.3 \times V_{g \min}$

Settings that are not listed in the table may lead to damage. Please contact us.

	150				170				215			
	$V_{g \max}$		$V_{g \min}$		$V_{g \max}$		$V_{g \min}$		$V_{g \max}$		$V_{g \min}$	
	[in ³ /rev (cm ³ /rev)]		[in ³ /rev (cm ³ /rev)]		[in ³ /rev (cm ³ /rev)]		[in ³ /rev (cm ³ /rev)]		[in ³ /rev (cm ³ /rev)]		[in ³ /rev (cm ³ /rev)]	
	from	to	from	to	from	to	from	to	from	to	from	to
A	9.28 (152.1)	9.28 (152.1)	0.0 (0.0)	2.68 (44.0)	10.48 (171.8)	10.48 (171.8)	0.0 (0.0)	2.14 (35.0)	13.21 (216.5)	13.21 (216.5)	0.0 (0.0)	2.72 (44.5)
	without screw		M12 × 80 R909153075		without screw		M12 × 80 R909153075		without screw		M12 × 80 R909153075	
B	9.28 (152.1)	9.28 (152.1)	> 2.68 (> 44.0)	4.21 (69.0)	10.48 (171.8)	10.48 (171.8)	> 2.14 (> 35.0)	3.87 (63.5)	13.21 (216.5)	13.21 (216.5)	> 2.72 (> 44.5)	4.88 (80.0)
	without screw		M12 × 90 R909154041		without screw		M12 × 90 R909154041		without screw		M12 × 90 R909154041	
C	9.28 (152.1)	9.28 (152.1)	> 4.21 (> 69.0)	6.04 (99.0)	10.48 (171.8)	10.48 (171.8)	> 3.87 (> 63.5)	5.98 (98.0)	13.21 (216.5)	13.21 (216.5)	> 4.88 (> 80.0)	7.02 (115.0)
	without screw		M12 × 100 R909153975		without screw		M12 × 100 R909153975		without screw		M12 × 100 R909153975	
D	9.28 (152.1)	9.28 (152.1)	> 6.04 (> 99.0)	6.04 (106.0)	10.48 (171.8)	10.48 (171.8)	> 5.98 (> 98.0)	9.15 (120.0)	13.21 (216.5)	13.21 (216.5)	> 7.02 (> 115.0)	9.15 (150.0)
	without screw		M12 × 110 R909154212		without screw		M12 × 110 R909154212		without screw		M12 × 110 R909154212	
E	< 9.28 (< 152.1)	6.77 (111.0)	0.0 (0.0)	2.68 (44.0)	< 10.48 (< 171.8)	8.48 (139.0)	0.0 (0.0)	2.14 (35.0)	< 13.21 (< 216.5)	10.68 (175.0)	0.0 (0.0)	2.72 (44.5)
	M12 × 80 R909153075		M12 × 80 R909153075		M12 × 80 R909153075		M12 × 80 R909153075		M12 × 80 R909153075		M12 × 80 R909153075	
F	< 9.28 (< 152.1)	6.77 (111.0)	> 2.68 (> 44.0)	4.21 (69.0)	< 10.48 (< 171.8)	8.48 (139.0)	> 2.14 (> 35.0)	3.87 (63.5)	< 13.21 (< 216.5)	10.68 (175.0)	> 2.72 (> 44.5)	4.88 (80.0)
	M12 × 80 R909153075		M12 × 90 R909154041		M12 × 80 R909153075		M12 × 90 R909154041		M12 × 80 R909153075		M12 × 90 R909154041	
G	< 9.28 (< 152.1)	6.77 (111.0)	> 4.21 (> 69.0)	6.04 (99.0)	< 10.48 (< 171.8)	8.48 (139.0)	> 3.87 (> 63.5)	3.86 (98.0)	< 13.21 (< 216.5)	10.68 (175.0)	> 4.88 (> 80.0)	7.02 (115.0)
	M12 × 80 R909153075		M12 × 100 R909153975		M12 × 80 R909153075		M12 × 100 R909153975		M12 × 80 R909153075		M12 × 100 R909153975	
H	< 9.28 (< 152.1)	6.77 (111.0)	> 6.04 (> 99.0)	6.47 (106.0)	< 10.48 (< 171.8)	8.48 (139.0)	> 3.86 (> 98.0)	7.32 (120.0)	< 13.21 (< 216.5)	10.68 (175.0)	> 7.02 (> 115.0)	9.15 (150.0)
	M12 × 80 R909153075		M12 × 110 R909154212		M12 × 80 R909153075		M12 × 110 R909154212		M12 × 80 R909153075		M12 × 110 R909154212	
J	< 6.77 (< 111.0)	5.31 (87.0)	0.0 (0.0)	2.68 (44.0)	< 8.48 (< 139.0)	6.83 (112.0)	0.0 (0.0)	2.14 (35.0)	< 10.68 (< 175.0)	8.60 (141.0)	0.0 (0.0)	2.72 (44.5)
	M12 × 90 R909154041		M12 × 80 R909153075		M12 × 90 R909154041		M10 × 80 R909153075		M12 × 90 R909154041		M12 × 80 R909153075	
K	< 6.77 (< 111.0)	5.31 (87.0)	> 2.68 (> 44.0)	4.21 (69.0)	< 8.48 (< 139.0)	6.83 (112.0)	> 2.14 (> 35.0)	3.87 (63.5)	< 10.68 (< 175.0)	8.60 (141.0)	> 2.72 (> 44.5)	4.88 (80.0)
	M12 × 90 R909154041		M12 × 90 R909154041		M12 × 90 R909154041		M12 × 90 R909154041		M12 × 90 R909154041		M12 × 90 R909154041	
L	< 6.77 (< 111.0)	5.31 (87.0)	> 4.21 (> 69.0)	6.04 (99.0)	< 8.48 (< 139.0)	6.83 (112.0)	> 3.87 (> 63.5)	5.98 (98.0)	< 10.68 (< 175.0)	8.60 (141.0)	> 4.88 (> 80.0)	7.02 (115.0)
	M12 × 90 R909154041		M12 × 100 R909153975		M12 × 90 R909154041		M12 × 100 R909153975		M12 × 90 R909154041		M12 × 100 R909153975	
M	< 6.77 (< 111.0)	5.31 (87.0)	> 6.04 (> 99.0)	6.47 (106.0)	< 8.48 (< 139.0)	6.83 (112.0)	> 5.98 (> 98.0)	7.32 (120.0)	< 10.68 (< 175.0)	8.60 (141.0)	> 7.02 (> 115.0)	9.15 (150.0)
	M12 × 90 R909154041		M12 × 110 R909154212		M12 × 90 R909154041		M12 × 110 R909154212		M12 × 90 R909154041		M12 × 110 R909154212	

Specify exact settings for $V_{g \min}$ and $V_{g \max}$ in plain text when ordering: $V_{g \min} = \dots \text{ in}^3 \text{ (cm}^3\text{)}$, $V_{g \max} = \dots \text{ in}^3 \text{ (cm}^3\text{)}$

Theoretical, maximum setting: ▶ for $V_{g \min} = 0.7 \times V_{g \max}$

▶ for $V_{g \max} = 0.3 \times V_{g \max}$

Settings that are not listed in the table may lead to damage. Please contact us.

Installation instructions

General

The axial piston unit must be filled with hydraulic fluid and air bled during commissioning and operation. This must also be observed following a longer standstill as the axial piston unit empty via the hydraulic lines.

Particularly in the installation position “drive shaft upwards”, filling and air bleeding must be carried out completely as there is, for example, a danger of dry running. The leakage in the housing area must be directed to the reservoir via the highest drain port (**T₁**, **T₂**).

For combinations of multiple units, make sure that the respective case pressure in each unit is not exceeded. In the event of pressure differences at the drain ports of the units, the shared drain line must be changed so that the maximum permissible case pressure of all connected units is not exceeded at any operational conditions.

If this is not possible, separate drain lines must be laid.

To achieve favorable noise values, decouple all connecting lines using elastic elements and avoid above-reservoir installation.

In all operating conditions, the drain line must flow into the reservoir below the minimum fluid level.

Note

In certain installation positions, an influence on the control characteristics can be expected. Gravity, dead weight and case pressure can cause minor shifts in control characteristic curves and changes in response time.

Key	
U	Bearing flushing / air bleed port
F	Filling / air bleeding
T₁, T₂	Drain port
$h_{t \min}$	Minimum required immersion depth (7.87 inch (200 mm))
h_{\min}	Minimum required distance to tank base (3.94 inch (100 mm))

Installation position

See examples **1** to **8** below.

Additional installation positions are available upon request.
Recommended installation position: **1** and **2**

Below-reservoir installation (standard)

Below-reservoir installation means that the axial piston unit is installed outside of the reservoir below the minimum fluid level.

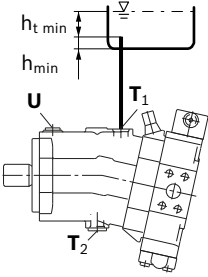
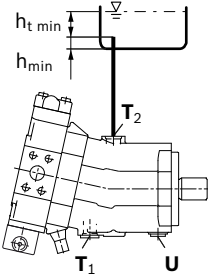
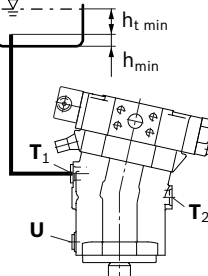
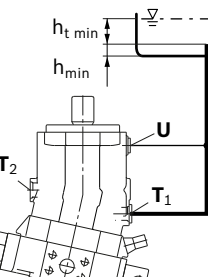
Installation position	Air bleed	Filling
1 		T₁
2 		T₂
3 		T₁
4 	U	T₁

Above-reservoir installation

Above-reservoir installation means that the axial piston unit is installed above the minimum fluid level of the reservoir.

Recommendation for installation position 8 (drive shaft upward):

A check valve in the drain line (cracking pressure 7.5 psi (0.5 bar)) can prevent draining of the motor housing.

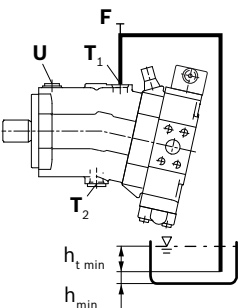
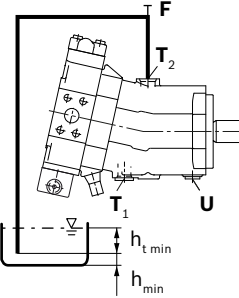
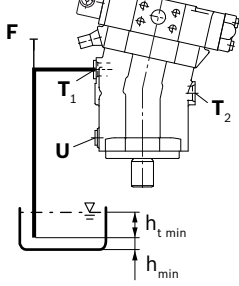
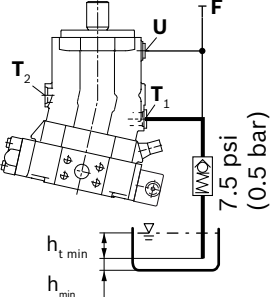
Installation position	Air bleed	Filling
<p>5</p> 	U (F)	T₁ (F)
<p>6</p> 	F	T₂ (F)
<p>7</p> 	F	T₁ (F)
<p>8</p> 	U	T₁ (F)

Note
 Port **F** is not part of the motor and can be provided by the customer to make filling and air bleeding easier.

Project planning notes

- ▶ The motor A6VM is designed to be used in open and closed circuits.
 - ▶ The project planning, installation and commissioning of the axial piston unit requires the involvement of qualified skilled person.
 - ▶ Before using the axial piston unit, please read the corresponding instruction manual completely and thoroughly. If necessary, these can be requested from Bosch Rexroth.
 - ▶ Before finalizing your design, request a binding installation drawing.
 - ▶ The data and notes contained herein must be adhered to.
 - ▶ For safety reasons, control systems with beginning of control at $V_{g \min}$ (e.g. HA) are not permissible for winch drives (e.g. anchor winches)!
 - ▶ Depending on the operating condition of the axial piston unit (operating pressure, fluid temperature), the characteristic may shift.
 - ▶ Preservation: Our axial piston units are supplied as standard with preservative protection for a maximum of 12 months. If longer preservative protection is required (maximum 24 months), please specify this in plain text when placing your order. The preservation times apply under optimal storage conditions, details of these conditions can be found in the data sheet 90312 or the instruction manual.
 - ▶ Not all variants of the product are approved for use in safety functions according to ISO 13849. Please consult the responsible contact person at Bosch Rexroth if you require reliability parameters (e.g. $MTTF_d$) for functional safety.
 - ▶ Depending on the type of control used, electromagnetic effects can be produced when using solenoids. Applying the recommended direct voltage signal (DC) to solenoids does not create electromagnetic interference (EMI) nor is the solenoid affected by EMI. Electromagnetic interference (EMI) potential exists when operating and controlling a proportional electrohydraulic coil with a Pulse Width Modulated (PWM) signal. Appropriate testing and measures should be taken by the machine manufacturer to ensure other components or operators (e.g. with pacemaker) are not affected by this potential.
 - ▶ Please note the details regarding the tightening torques of port threads and other threaded joints
- ▶ Working ports
 - The ports and fixing threads are designed for the specified peak pressure. The machine or system manufacturer must ensure that the connecting elements and lines correspond to the specified operating conditions (pressure, volume flow, hydraulic fluid, temperature) with the required safety factors.
 - The service and function ports are only designed to accommodate hydraulic lines

Safety instructions

- ▶ During and shortly after operation, there is a risk of burns on the axial piston unit and especially on the solenoids. Take appropriate safety measures (e.g., by wearing protective clothing).
- ▶ Moving parts in control equipment (e.g. valve pistons) can, under certain circumstances get blocked in position as a result of contamination (e.g. impure hydraulic fluid, abrasion, or residual dirt from components). As a result, the flow of hydraulic fluid and the build-up of momentum in the axial piston unit can no longer meet the operator's specifications. Even the use of various filter elements (external or internal flow filtering) cannot rule out errors, but can only help minimize risks. The machine/system manufacturer must check whether additional measures are required on the machine for the relevant application in order to bring the powered load into a safe position (e.g. safe stop) and ensure any measures are properly put into practice.
- ▶ In certain conditions, moving parts in high pressure relief valves might get stuck in an undefined position due to contamination. This can result in restriction or loss of load holding functions in lifting winches. Therefore it is the machine and/or system manufacturers responsibility to make sure that the load can always be put in a safe mode if needed. Also, he needs to ensure that these measures are properly implemented.
- ▶ When using the axial piston motor in winch drives, make certain that the technical limit values are not exceeded under all operating conditions. If the axial piston motor is extremely overloaded (e.g., if the maximum permissible rotational speeds are exceeded during weighing of the anchor while the ship is in motion), the rotary group may be damaged and, in the worst case, the axial piston motor may burst. The machine manufacturer / system manufacturer is to undertake additional measures, up to and including encapsulation.

Bosch Rexroth Corporation
Mobile Applications
8 Southchase Court
Fountain Inn, SC 29644-9018, USA
Telephone (864) 967-2777
Facsimile (864) 967-8900
www.boschrexroth-us.com

© This document, as well as the data, specifications and other information set forth in it, are the exclusive property of Bosch Rexroth Corporation. It may not be reproduced or given to third parties without its consent. The data specified above only serve to describe the product. No statements concerning a certain condition or suitability for a certain application can be derived from our information. The information given does not release the user from the obligation of own judgment and verification. It must be remembered that our products are subject to a natural process of wear and aging.